

SONY®



# BRC Series Systems

# Table of contents

<b>1</b>	<b>What is the BRC Series?</b>	4
<b>2</b>	<b>Product Lineup</b>	7
<b>3</b>	<b>Key Features</b>	8
<b>4</b>	<b>System Configuration</b>	10
	4.1 BRC-H700 Simple System	12
	4.2 BRC-H700/BRU-H700 System	12
	4.3 BRC-Z700 Simple System	13
	4.4 BRC-Z700/BRU-H700 System	13
	4.5 BRC-300/300P Simple System	13
	4.6 BRC-300/300P and BRU-300/300P System	14
	4.7 Daisy-chain System	14
<b>5</b>	<b>Location and Function of Parts</b>	15
	5.1 The BRC Series of Cameras	15
	5.1.1 BRC-H700	15
	5.1.2 BRC-Z700	16
	5.1.3 BRC-300/300P	18
	5.2 Optical Multiplex Units	19
	5.2.1 BRU-H700 HD Optical Multiplex Unit for use with the BRC-H700 and BRC-Z700	19
	5.2.2 BRU-300/300P SD Optical Multiplex Unit for use with the BRC-300/300P	20
	5.3 Optical Multiplex Cards and Optional Video Cards	20
	5.3.1 BRBK-H700 HD Optical Multiplex Card	20
	5.3.2 HFBK-HD1 HD Interface Board	21
	5.3.3 HFBK-SD1 SD Interface Board	21
	5.3.4 HFBK-XG1 XGA Interface Board	21
	5.3.5 HFBK-TS1 HDV Interface Board	21
	5.3.6 BRBK-MF1 HD Optical Multiplex Card	22
	5.3.7 BRBK-HSD1 HD/SD-SDI Output Card	22
	5.3.8 BRBK-303 SD Optical Multiplex Card	22
	5.3.9 BRBK-301 Analog RGB Component Card	22
	5.3.10 BRBK-302 SDI Card	22
	5.3.11 BRBK-304 i.LINK DV Card	22
<b>6</b>	<b>Basic Set-up and Operation</b>	23
	6.1 Connections	23
	6.2 Monitor Set-up	23
<b>7</b>	<b>Remote Operation</b>	24
	7.1 IR Remote Commander Unit	24
	7.2 RM-BR300 Remote Control Unit	25
	7.2.1 Features	25
	7.2.2 Operation	26
<b>8</b>	<b>Operation with the AWS-G500/G500HD Anycast Station</b>	33
	8.1 Controlling camera with the AWS-G500/G500HD Any cast station	33
	8.2 Controlling the camera with VISCA support	34
	8.3 Operating the PGM and NEXT Selection buttons from the RM-BR300	35
<b>9</b>	<b>Using the BRC-H700/BRC-Z700 as a Second Camera for the PCS-XG80 Video Conferencing System</b>	36
<b>10</b>	<b>Specifications</b>	37
<b>11</b>	<b>Dimensions</b>	39
<b>12</b>	<b>Technical Appendix</b>	43
	12.1 Color Adjustment	43
	12.2 Color Detail	43
	12.3 Estimated Viewing Angle of BRC Sereis	44
	12.4 Sync Lock Setting	48
	12.5 Recommended Lighting Conditions	48
	12.6 Using the VISCA RS-422 Connector Plug	48
	12.7 Wiring Diagram of VISCA RS-422 Connection	49
	12.8 CCFC Cable Information	50
<b>13</b>	<b>Installing the Camera in a High Position</b>	51

# What is the BRC Series?

The BRC Series consists of three cameras – the BRC-H700, the BRC-Z700, and the BRC-300/300P. They have very wide pan and tilt ranges, as well as extremely fast and accurate pan and tilt movements, making these cameras suitable for capturing not only fast-moving objects, but also slow-moving objects without rocking vibration. Moreover, you can operate each camera intuitively with the optional Sony RM-BR300 Remote Control Unit, which is equipped with an ergonomically designed joystick and a feature-rich control panel. With the RM-BR300, you can control up to seven cameras and change the presets and other parameters of each camera. In addition, long-distance control of the BRC Series can be achieved using an optical fiber connection.

With a number of useful features and excellent picture quality, the BRC Series is ideal for a variety of remote video shooting applications, in locations such as houses of worship, auditoriums, teaching hospitals, corporate boardrooms, and at sporting events, trade shows, and concerts. Furthermore, these cameras are a cost-effective choice for broadcast applications, such as television program recording and as weather cameras. As the three BRC Series cameras each have specific benefits, users can choose the most appropriate solution for their particular application needs.

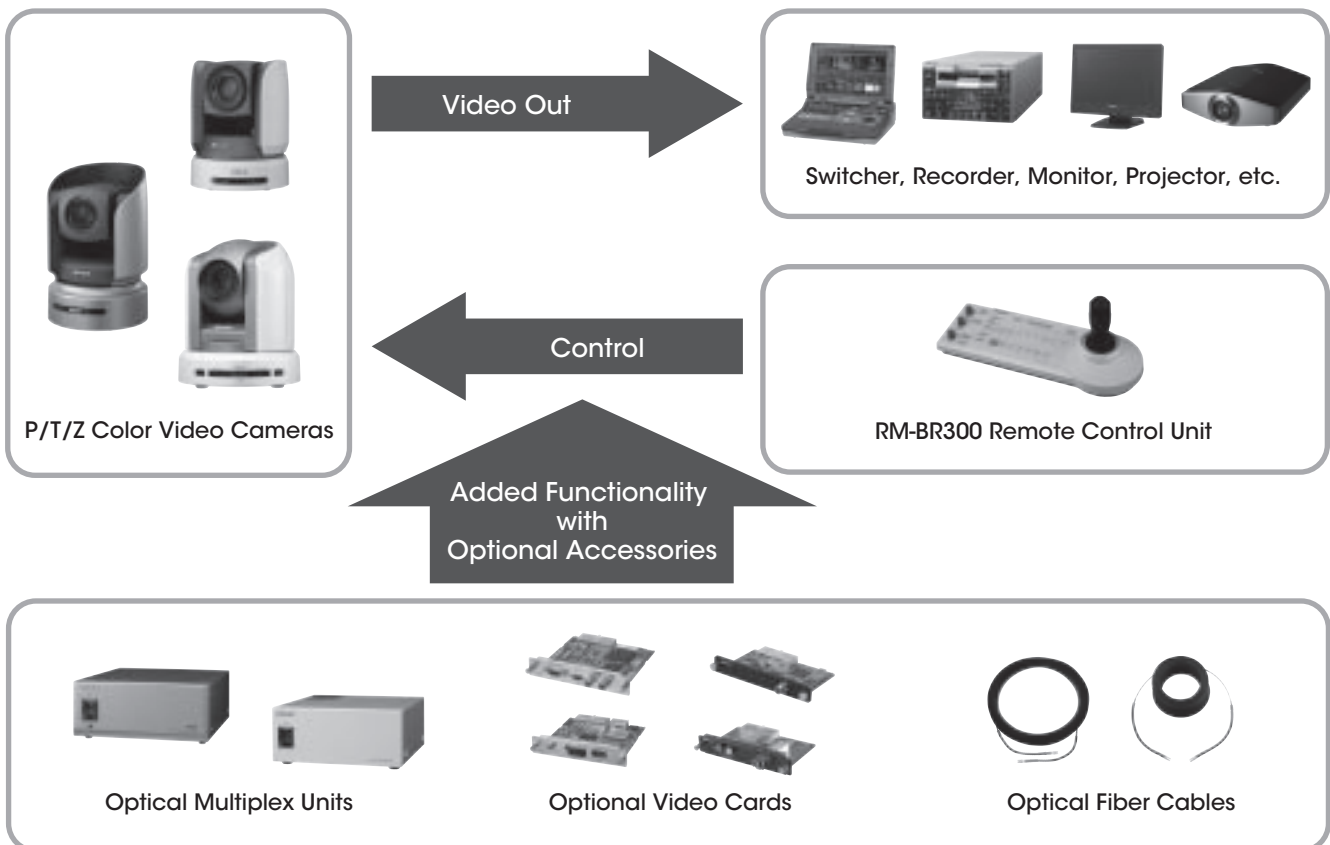

# Applications

## Education

The BRC Series brings you new educational opportunities by enabling real-time distribution and contents editing for distance learning. Moreover, the camera's stylish design and silent movement will complement any learning environment without distracting professors' and students' attention.

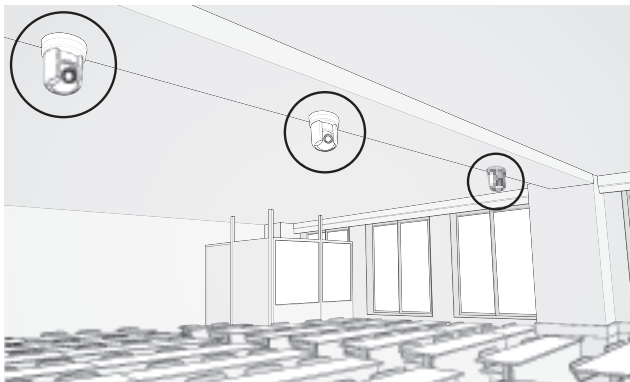

## City Council

With multiple preset positions and an intuitively controllable remote control unit, a single operator can capture and broadcast every moment of a live event without any technical knowledge. A tripod is recommended when you need flexible installation and camera operation.



## Auditorium/House of Worship

With a precise and smooth pan/tilt movement, and a zooming capability, you can attain optimum shooting with excellent picture quality. Moreover, by recalling preset positions with the benefit of a pre-specified optimal setting feature, you are not distracted and you can more easily follow ongoing events.

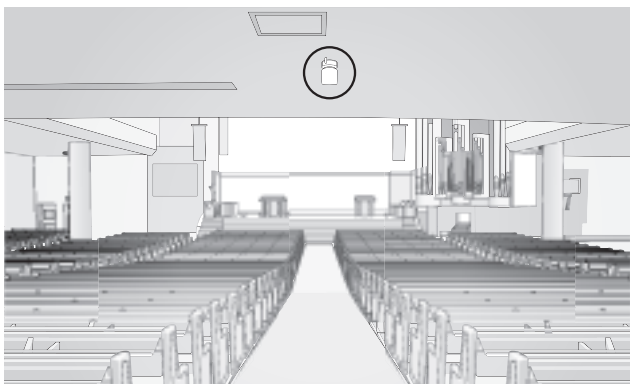

## Bridal

By pre-installing cameras on the ceiling, you can capture intimate and unrepeatable moments. These cameras will provide interesting new angles that are typically difficult for professional photographers to achieve. Furthermore, the unobtrusive design of these cameras is highly effective for capturing natural facial expressions and behavior. They do not interrupt or spoil the tranquility of proceedings.

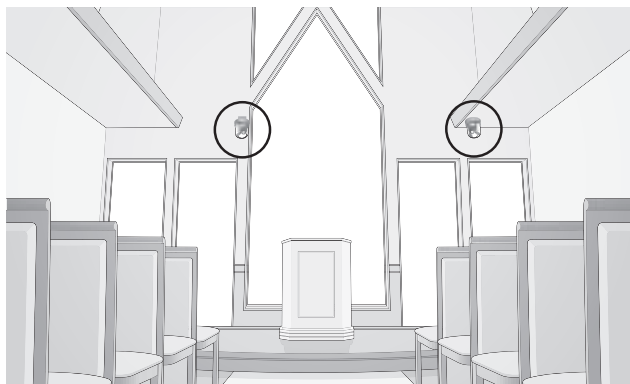

## Studio

For use as studio cameras, the BRC Series is equipped with a tally lamp, essential for effective TV program shooting and recording. In addition, the quiet Pan/Tilt mechanism meets highly demanding professional requirements.



## Boardroom

You can integrate the BRC Series into a video conference system. The camera's flexible installation capability means you can establish a video conferencing environment in an instant. In addition, the camera's high picture quality gives you more natural and effective networked communication.



# 2

## Product Lineup

### **BRC-H700 (HD 3CCD Color Video Camera)**

---

The BRC-H700 offers high picture quality and high sensitivity with three 1/3-type high-definition (HD) CCDs and a resolution of 1,120,000 total pixels. It is ideal if you require extremely clear HD images with great detail. Because of its high sensitivity, it can be operated in shooting environments without ideal lighting. Furthermore, it has the widest viewing angle in the BRC Series, allowing you to capture wide areas of a scene, such as the audience at concerts or in auditoriums.



### **BRC-Z700 (HD/SD 3CMOS Color Video Camera)**

---

The BRC-Z700 incorporates three 1/4-type HD ClearVid CMOS Sensors and achieves a resolution of 1,120,000 total pixels. It features a 20x optical auto-focus zoom lens with an optical image stabilizer, allowing you to clearly capture small or distant objects. The BRC-Z700 also offers dual HD/SD outputs and an enhanced Pan/Tilt mechanism that operates with extremely smooth and precise movements.



### **BRC-300/300P (SD 3CCD Color Video Camera)**

---

The standard-definition (SD) BRC-300/300P incorporates three 1/4.7-type Advanced HAD™ CCD sensors with a total of 1,070,000 pixels. It is an ideal camera for cost-effective SD applications – and it can capture images in both 4:3 and 16:9 aspect ratios, the latter offering a wider viewing angle. Furthermore, the BRC-300/300P is the smallest camera in the BRC Series, making it ideal in environments that require an unobtrusive camera.



# 3

## Key Features

### All-in-one P/T/Z Design

#### Stylish design suitable for most environments

The sleek design can complement almost any environment, including the interior décor of houses of worship, wedding halls, public spaces, and more.

#### Unobtrusive design ideal for reality shows and live events

The unobtrusive design of the BRC Series allows speakers and audiences to concentrate on discussions and lectures without being distracted. These inconspicuous cameras help to capture natural expressions and behavior.

### Cost Efficiency

While each camera in the BRC Series incorporates three CCD or CMOS image sensors, 12x to 20x zoom lenses, and P/T/Z movements, they are also reasonably priced, and are ideal for remote video shooting applications.

With outstanding functionality and a large number of peripheral components to choose from, you can design a variety of user-friendly systems.

### Long-distance Operation Using an Optical Fiber Cable

Uncompressed digital data – including video, external sync, and camera control signals – can be transmitted over a long distance using an optical multiplex unit, an optical multiplex card,

and an optical fiber cable. The maximum distance between the optical multiplex unit and the camera is 1000 m for the BRC-H700 and BRC-Z700, and 500 m for the BRC-300/300P.

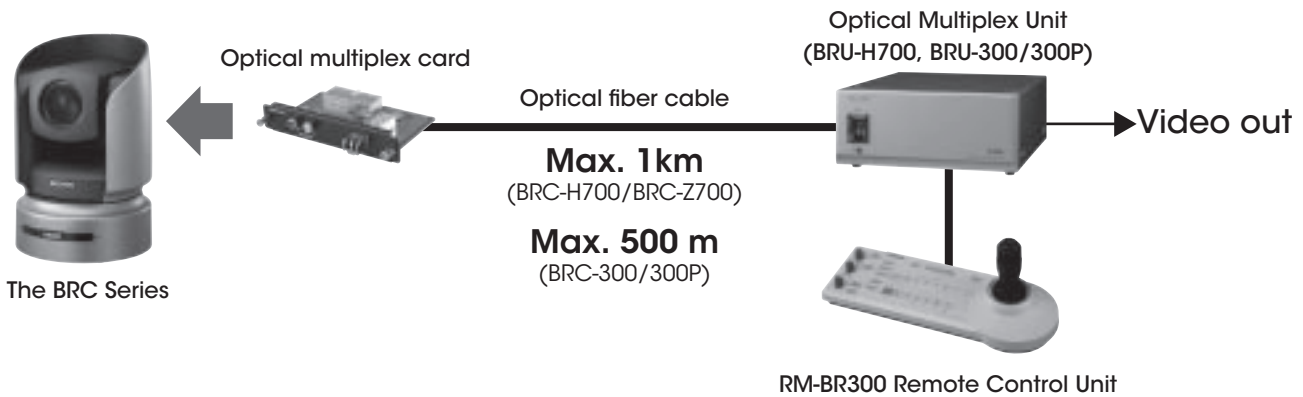

**Note** When using an optical fiber connection, optional video cards are used with the optical multiplex unit to provide a variety of video signals. In this configuration, camera video outputs are also available from the camera unit itself. When you use an optional multiplex card inserted into the camera, you cannot control the camera directly by the RM-BR300. You can control the camera only from the RM-BR300 through the BRU-H700 or BRU-300/300P.

## Versatile Video Outputs

By using optional video cards with the BRC Series, a variety of video signals can be output, enabling a wide range of system configurations.

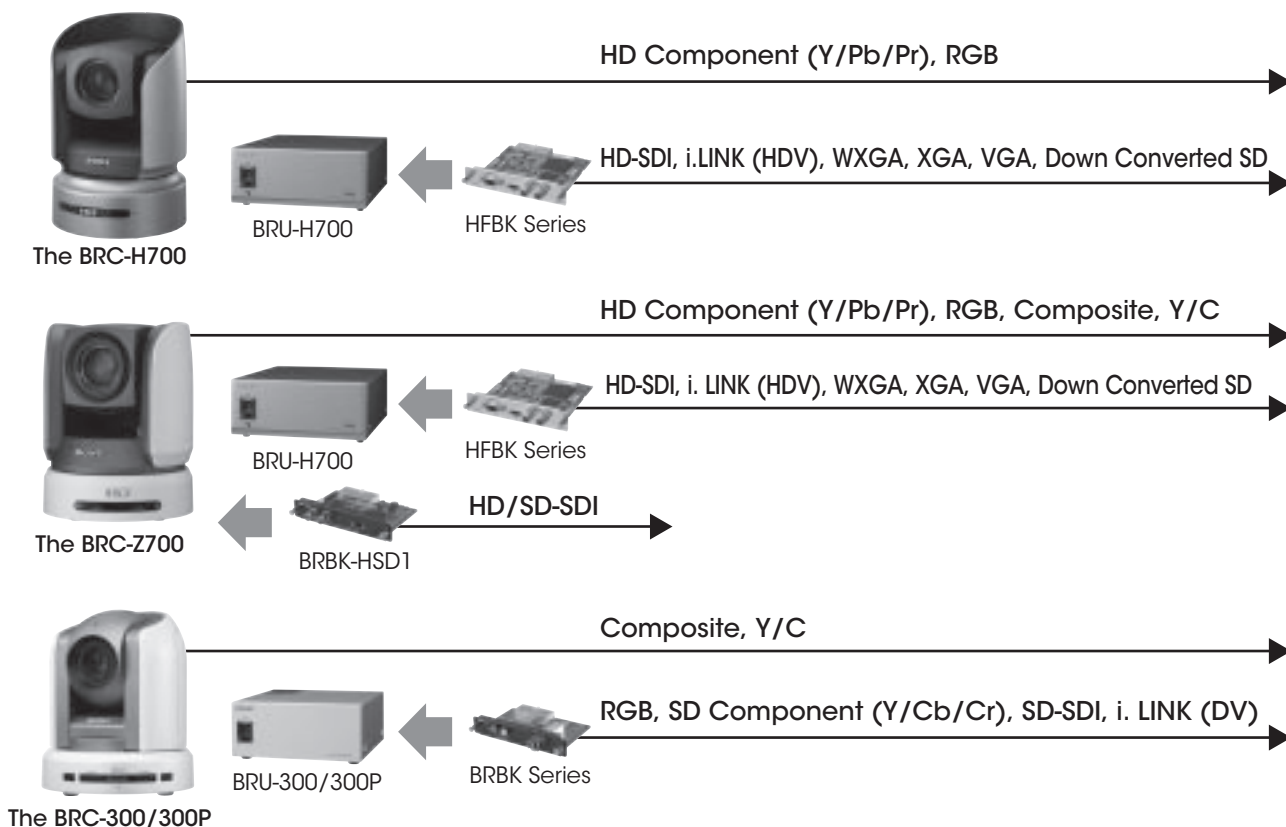

## Simultaneous Control of Seven Cameras

The RM-BR300 Remote Control Unit can be used to operate up to seven cameras.

## Other Features

### Flexible installation

The BRC Series can be placed on a desktop, mounted on the ceiling, used with a tripod, or installed in an outdoor housing kit, depending on your applications.



Flat surface



Ceiling Mount



Placed on a tripod



Outdoor Housing Kit

**Note** BRC Series cameras can be ceiling-mounted with a supplied ceiling bracket and screws. For use with a tripod, the camera has a standard 1/4-20 UNC receptor. For the tripod and the outdoor housing kit, please contact to the regional headquarters.

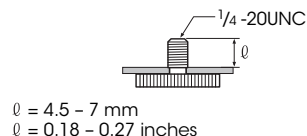

### Multiple presets















The BRC-H700 and BRC-Z700 each have sixteen presets and the BRC-300/300P has six presets to which pre-defined pan/tilt/zoom positions and other parameters can be allocated. These presets can be recalled at the touch of a button of the RM-BR300 or the IR remote commander unit to easily capture video from pre-specified areas.





















# 4

## System Configuration

You can configure a variety of systems to meet your application needs by choosing HD and/or SD components. Users can choose either HD or SD system components.

BRC Simple System			
	 <p><b>BRC-H700</b></p>	 <p><b>BRC-Z700</b></p>	 <p><b>BRC-300/300P</b></p>
Wide Conversion Lens	-	 <p><b>VCL-HG0862*</b></p>	 <p><b>VCL-0737W</b></p>
Optical Video Card (inserted to the BRC Series)	 <p><b>HFBK-HD1</b> HD-SDI, HD Component (Y/Pb/Pr), RGB</p>	 <p><b>BRBK-HSD1</b> HD-SDI, SD-SDI</p>	 <p><b>BRBK-301</b> Composite, Y/C, SD Component (Y/Cb/Cr), RGB</p>
	 <p><b>HFBK-SD1</b> SD-SDI, Composite, Y/C, SD Component (Y/Cb/Cr), RGB</p>		 <p><b>BRBK-302</b> SD-SDI</p>
	 <p><b>HFBK-TS1</b> i.LINK (HDV)</p>		 <p><b>BRBK-304</b> i.LINK (DV)</p>
	 <p><b>HFBK-XG1</b> WXGA, XGA, VGA</p>		
Remote Control unit	 <p><b>RM-BR300</b></p>		

\*The lens hood supplied with the VCL-HG0862K cannot be used.

BRC and BRU System			
	<b>BRC-H700</b> 	<b>BRC-Z700</b> 	<b>BRC-300/300P</b> 
Wide Conversion Lens	-	<b>VCL-HG0862*</b> 	<b>VCL-0737W</b> 
Optical Multiplex Card (inserted to the BRC Series)	<b>BRBK-H700</b> 	<b>BRBK-MF1</b> 	<b>BRBK-303</b> 
Optical Fiber Cable	<b>CCFC-M100HG</b> 		<b>CCFC-M100</b> 
Optical Multiplex Unit	<b>BRU-H700</b> 		<b>BRU-300/300P</b> 
Optical Video Card (inserted to the Optical Multiplex unit)	<b>HFBK-HD1</b> HD-SDI, HD Component (Y/Pb/Pr), RGB 		<b>BRBK-301</b> Composite, Y/C, SD Component (Y/Cb/Cr), RGB 
	<b>HFBK-SD1</b> SD-SDI, Composite, Y/C, SD Component (Y/Cb/Cr), RGB 		
	<b>HFBK-TS1</b> i.LINK (HDV) 		<b>BRBK-302</b> SD-SDI 
	<b>HFBK-XG1</b> WXGA, XGA, VGA 		<b>BRBK-304</b> i.LINK (DV) 

## 4.1 BRC-H700 Simple System

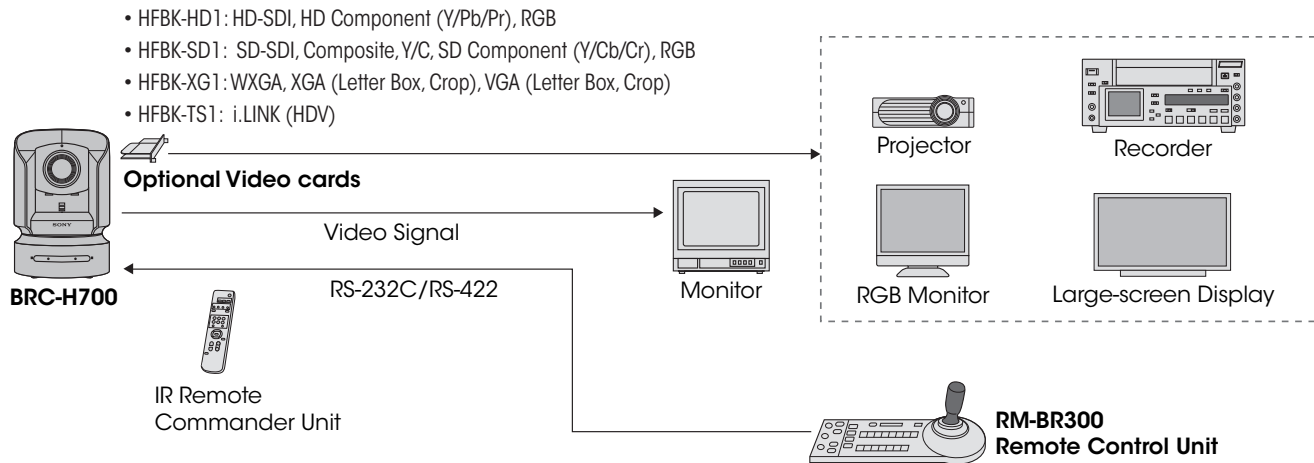

## 4.2 BRC-H700 and BRU-H700 System

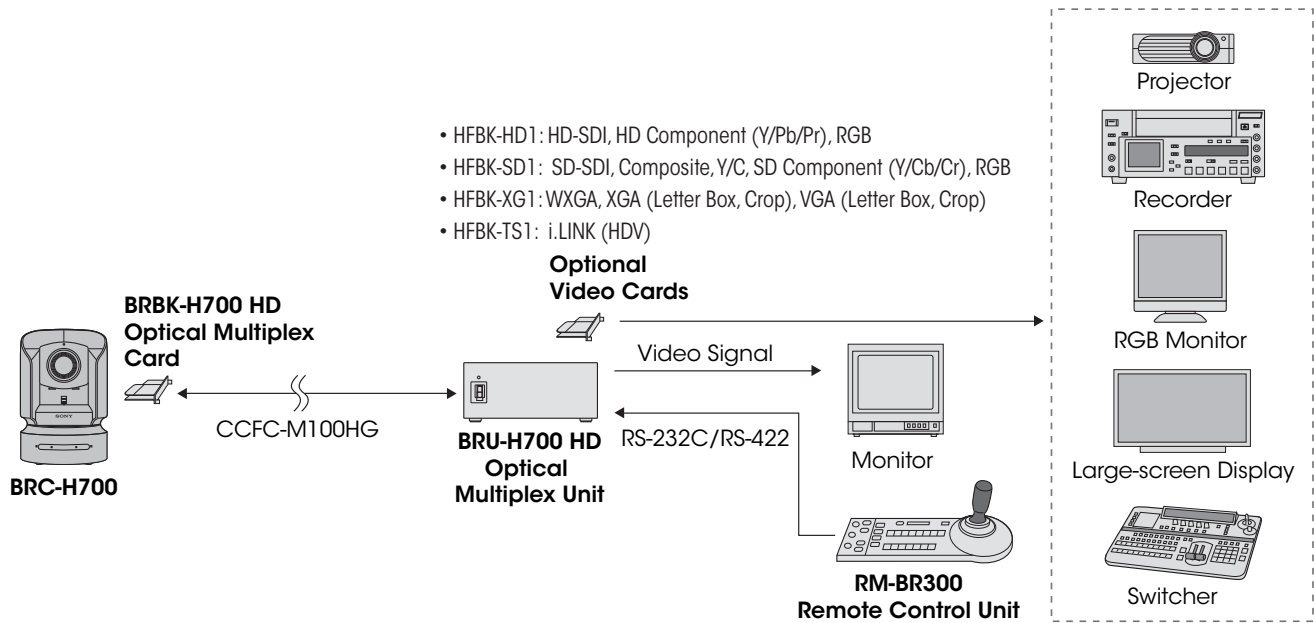

## 4.3 BRC-Z700 Simple System

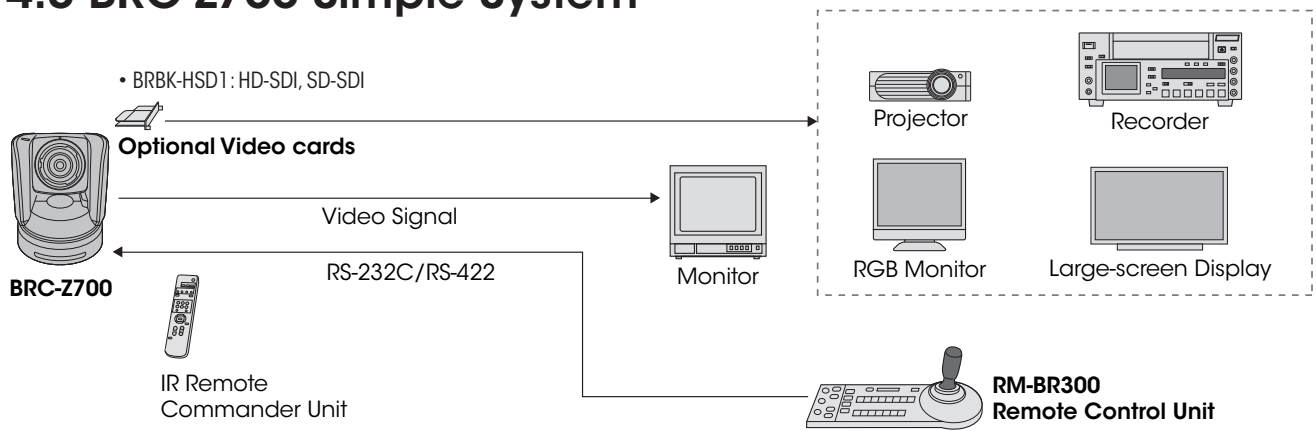

## 4.4 BRC-Z700 and BRU-H700 System

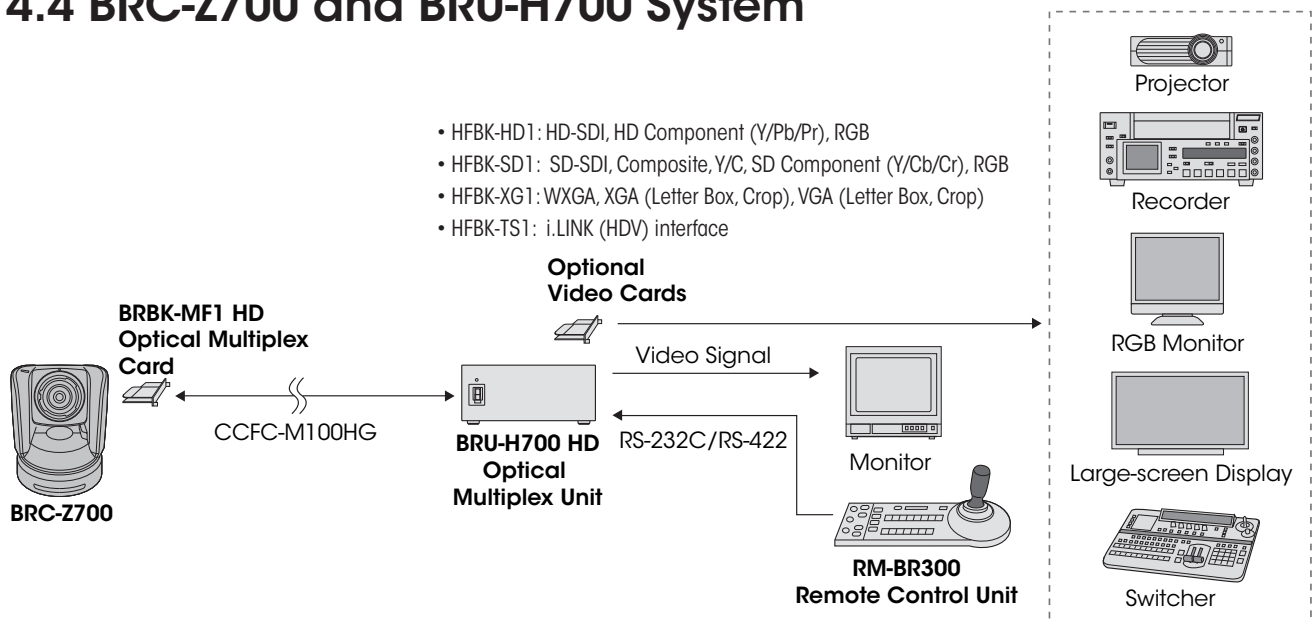

## 4.5 BRC-300/300P Simple System

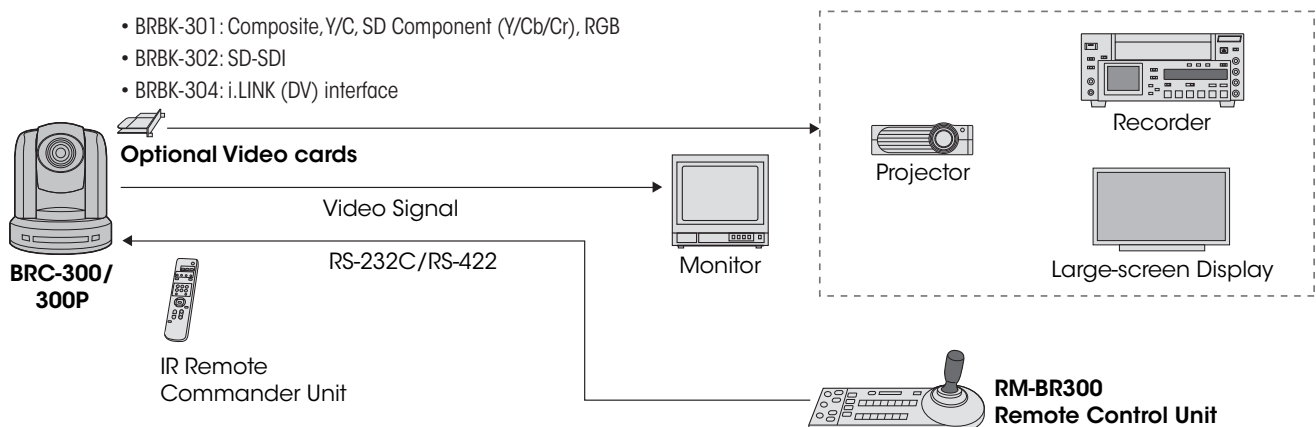

## 4.6 BRC-300/300P and BRU-300/300P System

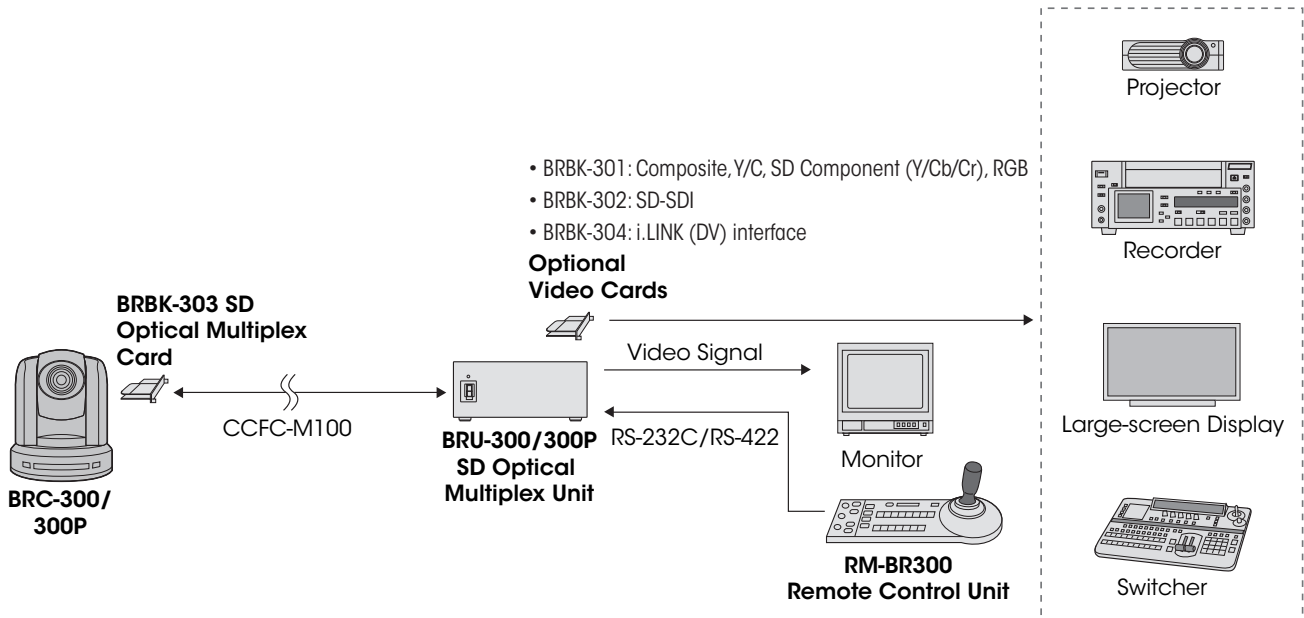

## 4.7 Daisy-chain System

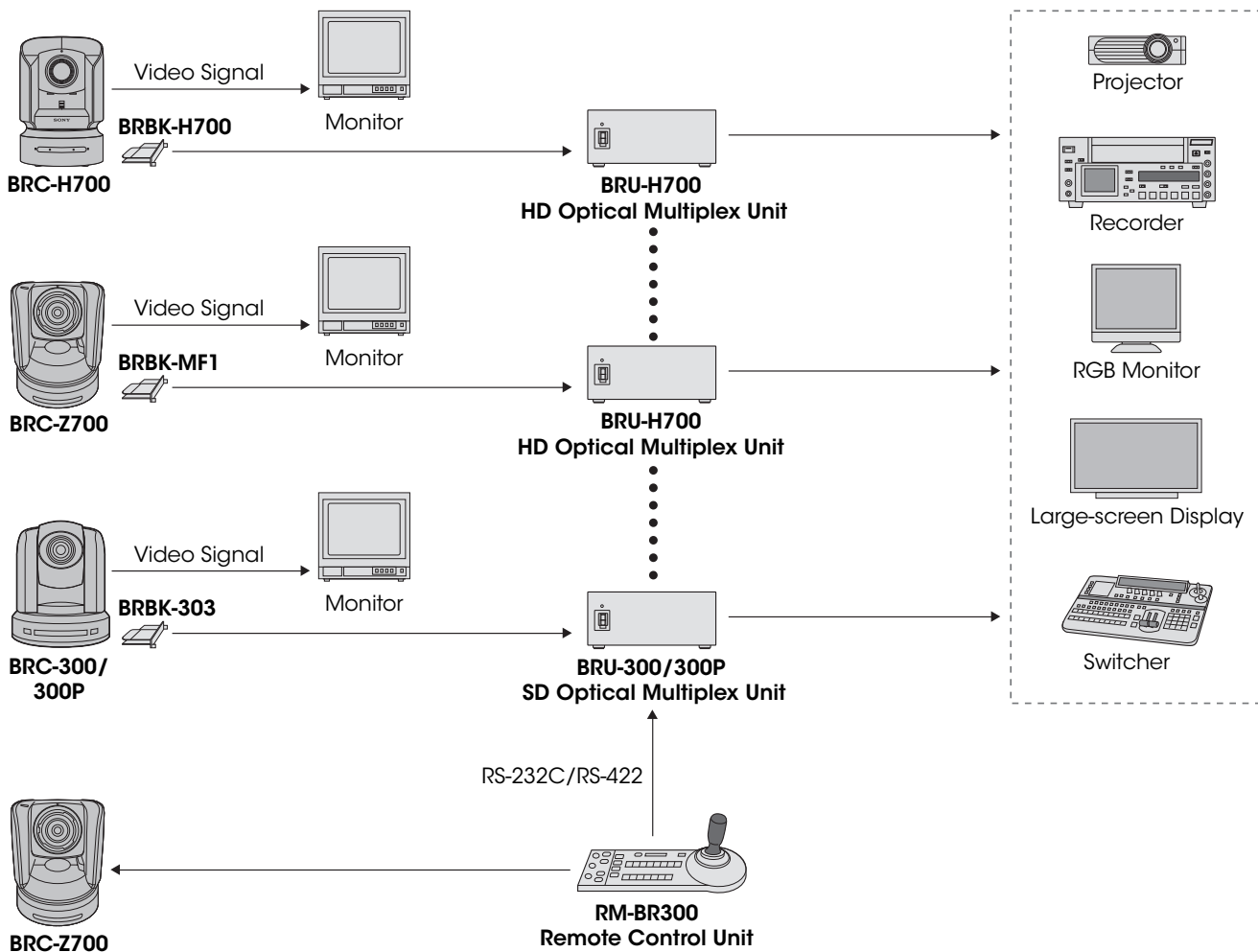

# 5

## Location and Function of Parts

### 5.1 BRC Series of Cameras

The following is a summary of the location and function of BRC-H700, BRC-Z700, and BRC-300/300P parts.

#### 5.1.1 BRC-H700

Rear

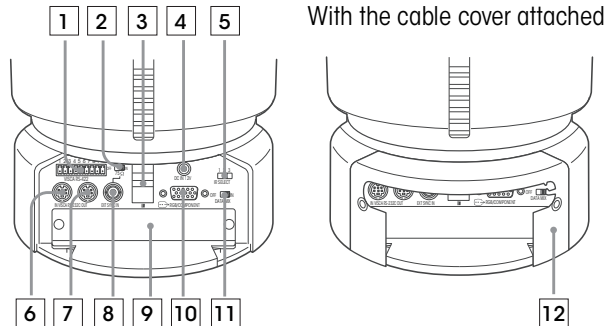

**1 VISCA RS-422 connector**

**2 75 Ω termination switch**

This switch is used when an external sync signal is utilized. Set it to OFF when the camera is in the middle of a daisy-chain connection of multiple cameras. Set it to ON when the camera is at the end of a daisy-chain connection.

**3 Remote sensor**

This is the sensor for the supplied IR Remote Commander Unit.

**4 DC IN 12V connector**

**5 IR SELECT switch**

Selects the camera number when you operate multiple cameras with the same IR Remote Commander Unit.

**6 VISCA RS-232C IN connector**

Connects to the RM-BR300 Remote Control Unit. When you join multiple cameras, connect it to the VISCA RS-232C OUT connector of the previous camera in the daisy chain.

**7 VISCA RS-232C OUT connector**

When you join multiple cameras, connect it to the VISCA RS-232C IN connector of the next camera in the daisy chain.

**8 EXT SYNC IN connector**

**9 Card slot**

**10 RGB/COMPONENT connector**

Pin No.	Signal	Pin No.	Signal
1	Pr/R	9	NC
2	Y/G	10	GND
3	Pb/B	11	GND
4	GND	12	NC
5	GND	13	HD-OUT
6	GND	14	Tri-level Sync/Bi-level VD
7	GND	15	NC
8	GND		

**11 DATA MIX switch**

Set the switch to ON to overlap the menu with the video signal output from the installed interface board. Set it to OFF not to overlap the menu.

**12 Cable cover**

Bottom

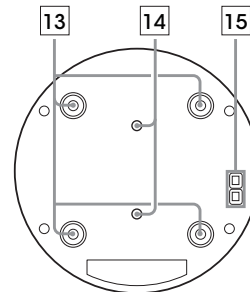

**13 Ceiling bracket mounting screw holes**

**14 Tripod screw holes (1/4-20UNC)**

**15 BOTTOM switches**

## Setting of the BOTTOM switches

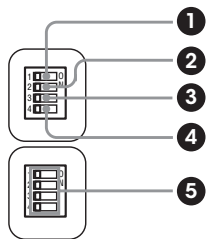

- 1 Switch 1 (59.94i/50i signal format selector)**  
Set to ON for output of 50i signal format, or OFF for output of 59.94i signal format.
- 2 Switch 2 (RS-232C/RS-422 selector)**  
Set to ON for RS-422, or OFF for RS-232C.
- 3 Switch 3 (Communication baud rate selector)**  
Set to ON for 38400 bps, or OFF for 9600 bps.
- 4 Switch 4 (Infrared signal output switch)**  
Set to ON to enable an infrared signal output, or OFF to disable the output.
- 5 Camera address selectors**  
Set the address of the camera. Normally set to 0. With this setting, addresses are assigned to the cameras automatically in the connected order by pressing the POWER button while holding down the RESET button on the RM-BR300 Remote Control Unit. You can assign the camera address, 1 to 7, manually by setting these selectors as follows:

Camera address	0	1	2	3	4	5	6	7
Switch 1	OFF	ON	OFF	ON	OFF	ON	OFF	ON
Switch 2	OFF	OFF	ON	ON	OFF	OFF	ON	ON
Switch 3	OFF	OFF	OFF	OFF	ON	ON	ON	ON

Switch 4 is not used.

**Note** Please note that the same camera address cannot be assigned to two or more different cameras. Furthermore, you must set the switches before you turn on camera power.

## 5.1.2 BRC-Z700

Rear

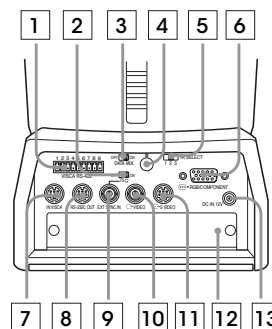

- 1 VISCA RS-422 connector**
- 2 75 Ω termination switch**  
This switch is used when an external sync signal is utilized. Set it to OFF when this camera is in the middle of a daisy-chain connection of multiple cameras. Set it to ON when the camera is at the end of a daisy-chain connection or when nothing is connected to the EXT SYNC IN connector on the camera.
- 3 DATA MIX switch**  
Set the switch to ON to overlap the menu with the video signal output from the installed interface board. Set it to OFF not to overlap the menu.
- 4 Remote sensor**  
This is the sensor for the supplied IR Remote Commander Unit. This remote sensor does not function when IMGFLIP is set to ON in the SYSTEM menu.
- 5 IR SELECT switch**  
Selects the camera number when you operate multiple cameras with the same IR Remote Commander Unit.
- 6 RGB/COMPONENT connector**

Pin No.	Signal	Pin No.	Signal
1	Pr/R	9	NC
2	Y/G	10	GND
3	Pb/B	11	GND
4	GND	12	NC
5	GND	13	HD-OUT
6	GND	14	Tri-level Sync/Bi-level VD
7	GND	15	NC
8	GND		
- 7 VISCA RS-232C IN connector**  
Connects to the RM-BR300 Remote Control Unit. When you join multiple cameras, connect it to the VISCA RS-232C OUT connector of the previous camera in the daisy chain.

**8 VISCA RS-232C OUT connector**

When you join multiple cameras, connect it to the VISCA RS-232C IN connector of the next camera in the daisy chain.

**9 EXT SYNC IN connector**

**10 VIDEO connector (Composite out)**

**11 S-VIDEO connector**

**12 Card slot**

**13 DC IN 12V connector**

Bottom

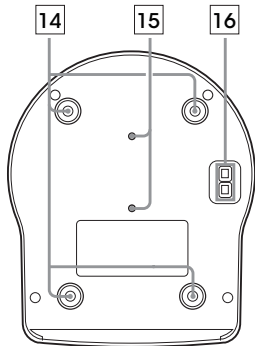

**14 Ceiling bracket mounting screw holes**

**15 Tripod screw holes (1/4-20UNC)**

**16 BOTTOM switches**

Setting of the BOTTOM switches

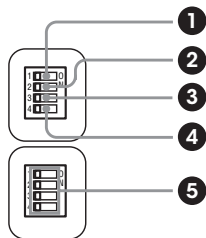

**1 Switch 1 (59.94i/50i signal format selector)**

Set to ON for output of 50i signal format, or OFF for output of 59.94i signal format.

**2 Switch 2 (RS-232C/RS-422 selector)**

Set to ON for RS-422, or OFF for RS-232C.

**3 Switch 3 (Communication baud rate selector)**

Set to ON for 38400 bps, or OFF for 9600 bps.

**4 Switch 4 (Infrared signal output switch)**

Set to ON to enable an infrared signal output, or OFF to disable the output.

**5 Camera address selectors**

Set the address of the camera. Normally set to 0. With this setting, addresses are assigned to the cameras automatically in the connected order by pressing the POWER button while holding down the RESET button on the RM-BR300 Remote Control Unit. You can assign the camera address, 1 to 7, manually by setting these selectors as follows:

Camera address	0	1	2	3	4	5	6	7
Switch 1	OFF	ON	OFF	ON	OFF	ON	OFF	ON
Switch 2	OFF	OFF	ON	ON	OFF	OFF	ON	ON
Switch 3	OFF	OFF	OFF	OFF	ON	ON	ON	ON

Switch 4 is not used.

**Note** Please note that the same camera address cannot be assigned to two or more different cameras. Furthermore, you must set the switches before you turn on camera power.



## 5.1.3 BRC-300/300P

Rear

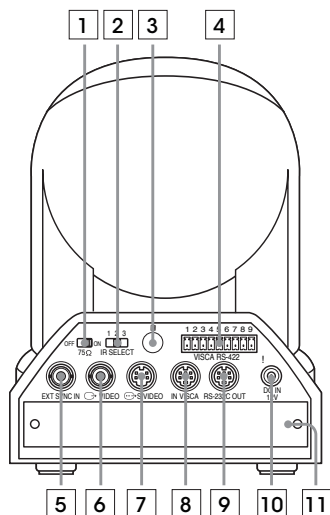

### 1 75 Ω termination switch

This switch is used when an external sync signal is utilized. Set it to OFF when this camera is in the middle of a daisy-chain connection of multiple cameras. Set it to ON when the camera is at the end of a daisy-chain connection.

### 2 IR SELECT switch

Selects the camera number when you operate multiple cameras with the same IR Remote Commander Unit.

### 3 Remote sensor

This is the sensor for the supplied IR Remote Commander Unit.

### 4 VISCA RS-422 connector

### 5 EXT SYNC IN connector

### 6 VIDEO connector (Composite out)

### 7 S-VIDEO connector

### 8 VISCA RS-232C IN connector

Connects to the RM-BR300 Remote Control Unit. When you join multiple cameras, connect it to the VISCA RS-232C OUT connector of the previous camera in the daisy chain.

### 9 VISCA RS-232C OUT connector

When you join multiple cameras, connect it to the VISCA RS-232C IN connector of the next camera in the daisy chain.

### 10 DC IN 12V connector

### 11 Card slot

Bottom

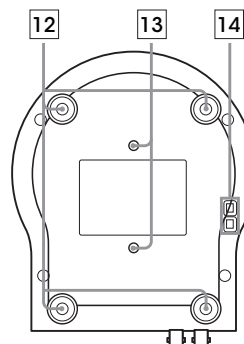

### 12 Ceiling bracket mounting screw holes

### 13 Tripod screw holes (1/4-20UNC)

### 14 BOTTOM switches

## Setting of the BOTTOM switches

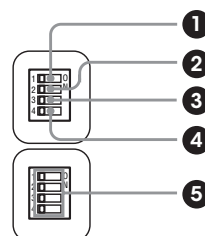

### 1 Switch 1 (No connection)

Always keep it OFF.

### 2 Switch 2 (RS-232C/RS-422 selector)

Set to ON for RS-422, or OFF for RS-232C.

### 3 Switch 3 (Communication baud rate selector)

Set to ON for 38400 bps, or OFF for 9600 bps.

### 4 Switch 4 (Infrared signal output switch)

Set to ON to enable an infrared signal output, or OFF to disable the output.

### 5 Camera address selectors

Set the address of the camera. Normally set to 0. With this setting, addresses are assigned to the cameras automatically in the connected order by pressing the POWER button while holding down the RESET button on the RM-BR300 Remote Control Unit. You can assign the camera address, 1 to 7, manually by setting these selectors as follows:

Camera address	0	1	2	3	4	5	6	7
Switch 1	OFF	ON	OFF	ON	OFF	ON	OFF	ON
Switch 2	OFF	OFF	ON	ON	OFF	OFF	ON	ON
Switch 3	OFF	OFF	OFF	OFF	ON	ON	ON	ON

Switch 4 is not used.

**Note** Please note that the same camera address cannot be assigned to two or more different cameras. Furthermore, you must set the switches before you turn on camera power.

## 5.2 Optical Multiplex Units

The following provides information on the location and function of BRU-H700 and BRU-300/300P parts. With these optical multiplex units, you can transmit uncompressed digital data including video, external sync, and camera control signals.

### 5.2.1 BRU-H700 HD Optical Multiplex Unit for use with the BRC-H700 and BRC-Z700

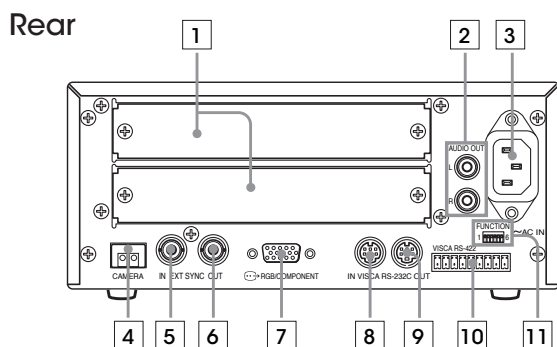

#### 1 Card slot

#### 2 AUDIO OUT L/R jacks

Loop through output of the audio line signal input from the AUDIO IN jacks on the BRBK-H700 HD Optical Multiplex Card or BRBK-MF1 HD Optical Multiplex Card inserted into the camera via an optical fiber cable.

#### 3 ~AC IN connector

#### 4 CAMERA connector

#### 5 EXT SYNC IN connector

#### 6 EXT SYNC OUT connector

#### 7 RGB/COMPONENT connector

Pin No.	Signal	Pin No.	Signal
1	Pr/R	9	NC
2	Y/G	10	GND
3	Pb/B	11	GND
4	GND	12	NC
5	GND	13	HD-OUT
6	GND	14	Tri-level Sync/Bi-level VD
7	GND	15	NC
8	GND		

#### 8 VISCA RS-232C IN connector

Connect to the RM-BR300 Remote Control Unit. When you join multiple cameras, connect it to the VISCA RS-232C OUT connector of the previous camera in the daisy chain.

#### 9 VISCA RS-232C OUT connector

When you join multiple cameras, connect it to the VISCA RS-232C IN connector of the next camera in the daisy chain.

#### 10 VISCA RS-422 connector

#### 11 VISCA FUNCTION switches

##### Switch 1 (RS-232C/RS-422 selector)

Set to ON for RS-422, or OFF for RS-232C.

##### Switch 2 (Communication baud rate selector)

Set to ON for 38400 bps, or OFF for 9600 bps.

##### Switches 3 to 5 (Camera address selectors)

Set the address of the camera. Normally set to 0. With this setting, addresses are assigned to the cameras automatically in the connected order by pressing the POWER button while holding down the RESET button on the RM-BR300 Remote Control Unit. You can assign the camera address, 1 to 7, manually by setting these selectors as follows:

Camera address	0	1	2	3	4	5	6	7
Switch 3	OFF	ON	OFF	ON	OFF	ON	OFF	ON
Switch 4	OFF	OFF	ON	ON	OFF	OFF	ON	ON
Switch 5	OFF	OFF	OFF	OFF	ON	ON	ON	ON

**Note** Please note that the same camera address cannot be assigned to two or more different cameras.

##### Switch 6 (59.94i/50i signal format selector)

Set to ON for output of 50i signal format, or OFF for output of 59.94i signal format.

**Note** Please further note that you must set the switches before you turn on power to the multiplex unit.

## 5.2.2 BRU-300/300P SD Optical Multiplex Unit for use with the BRC-300/300P

Rear

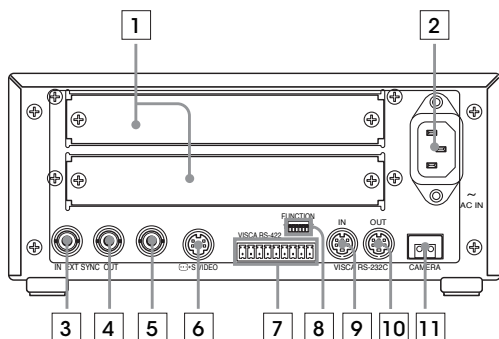

- 1 Card slot
- 2 AC IN connector
- 3 EXT SYNC IN connector
- 4 EXT SYNC OUT connector
- 5 Composite video output connector
- 6 S-VIDEO connector
- 7 VISCA RS-422 connector
- 8 VISCA FUNCTION switches
  - Switch 1 (RS-232C/RS-422 selector)**  
Set to ON for RS-422, or OFF for RS-232C.
  - Switch 2 (Communication baud rate selector)**  
Set to ON for 38400 bps, or OFF for 9600 bps.

### Switches 3 to 5 (Camera address selectors)

Set the address of the camera. Normally set to 0. With this setting, addresses are assigned to the cameras automatically in the connected order by pressing the POWER button while holding down the RESET button on the RM-BR300 Remote Control Unit. You can assign the camera address, 1 to 7, manually by setting these selectors as follows:

Camera address	0	1	2	3	4	5	6	7
Switch 3	OFF	ON	OFF	ON	OFF	ON	OFF	ON
Switch 4	OFF	OFF	ON	ON	OFF	OFF	ON	ON
Switch 5	OFF	OFF	OFF	OFF	ON	ON	ON	ON

Switch 6 is not used.

**Note** Please note that the same camera address cannot be assigned to two or more different cameras.

- 9 VISCA RS-232C IN connector  
Connect to the RM-BR300 Remote Control Unit. When you join multiple cameras, connect it to the VISCA RS-232C OUT connector of the previous camera in the daisy chain.
- 10 VISCA RS-232C OUT connector  
When you join multiple cameras, connect it to the VISCA RS-232C IN connector of the next camera in the daisy chain.
- 11 CAMERA connector

## 5.3 Optical Multiplex Cards and Optional Video Cards

The following provides information on the location and function of optical multiplex card parts and optional video cards and optional video cards. The BRC Series allows you to choose from a wide range of optional video cards. This versatility enables you to create flexible analog and digital system configurations.

### 5.3.1 BRBK-H700 HD Optical Multiplex Card

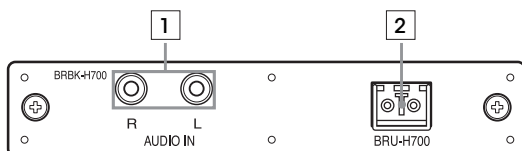

- 1 AUDIO IN L/R jacks (phono-type)  
Input an audio signal (stereo) that is output from the AUDIO OUT jacks on the BRBK-H700 HD Optical Multiplex Card via an optical fiber cable. The audio input on this board accepts audio line signals only. When you input audio signals from a microphone or similar device, it should be connected with a microphone amplifier so that audio signals with an appropriate audio level can be input.
- 2 Optical connector

### 5.3.2 HFBK-HD1 HD Interface Board

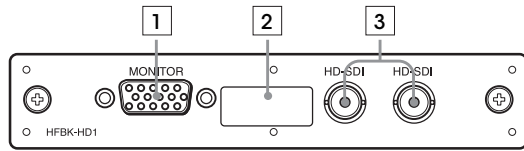

**1 MONITOR connector (D-sub 15-pin)**

Pin No.	Signal	Pin No.	Signal
1	R/Pr (X)	9	NC
2	G/Y (X)	10	GND
3	B/Pb (X)	11	NC
4	NC	12	NC
5	GND	13	HD
6	R/Pr (G)	14	VD/SYNC
7	G/Y (G)	15	NC
8	B/Pb (G)		

**2 DIP switches (inside the cap)**

When this interface board is inserted into the camera or the BRU-H700 HD Optical Multiplex Unit, the DIP switches cannot be used. The parameters can be set from the menu of the camera.

**3 HD-SDI connector (BNC-type)**

Supplies HD-SDI signals that conform to the SMPTE292M serial digital interface standard. The two connectors output the same signal.

### 5.3.3 HFBK-SD1 SD Interface Board

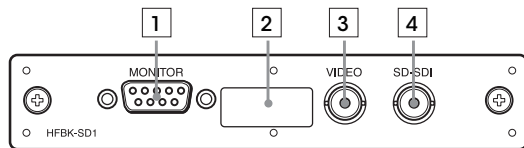

**1 MONITOR connector (D-sub 9-pin)**

Pin No.	Signal	Pin No.	Signal
1	GND	6	Composite/Y
2	GND	7	SYNC
3	R/Cr	8	GND
4	G/Y	9	-/C
5	B/Cb		

**2 DIP switches (inside the cap)**

When this interface board is inserted into the camera or the BRU-H700 HD Optical Multiplex Unit, the DIP switches cannot be used. The parameters can be set from the menu of the camera.

**3 VIDEO connector (BNC-type)**

Supplies analog composite signals. The aspect ratio can be selected in the camera's DOWN CONVERTER menu.

**4 SD-SDI connector (BNC-type)**

Supplies down-converted SD-SDI signals that conform to SMPTE259M (for 59.94i signal format) and ITU-R BT.656 (for 50i signal format) serial digital interface standards. The aspect ratio can be selected with the camera's DOWN CONVERTER menu.

### 5.3.4 HFBK-XG1 XGA Interface Board

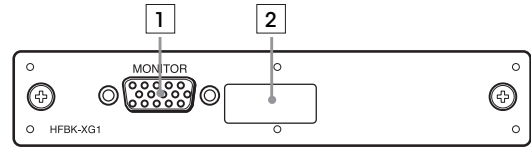

**1 MONITOR connector (D-sub 15-pin)**

Pin No.	Signal	Pin No.	Signal
1	R (X)	9	NC
2	G (X)	10	GND
3	B (X)	11	NC
4	NC	12	NC
5	GND	13	HD
6	R (G)	14	VD
7	G (G)	15	NC
8	B (G)		

**2 DIP switches (inside the cap)**

When this interface board is inserted into the camera or the BRU-H700 HD Optical Multiplex Unit, the DIP switches cannot be used. The parameters can be set from the menu of the camera.

### 5.3.5 HFBK-TS1 HDV Interface Board

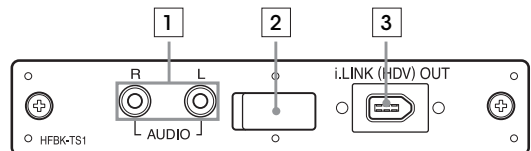

**1 AUDIO L/R jacks (phono-type)**

Input audio signals (stereo). The input audio signals are converted into signals that comply with HDV standards. The time difference between image and audio can be adjusted by up to 240 minutes in 10 increments.

**2 DIP switches (inside the cap)**

When this interface board is inserted into the camera or the BRU-H700 HD Optical Multiplex Unit, the DIP switches cannot be used. The parameters can be set from the menu of the camera.

**3 i.LINK (HDV) OUT connector (i.LINK 6-pin)**

### 5.3.6 BRBK-MF1 HD Optical Multiplex Card

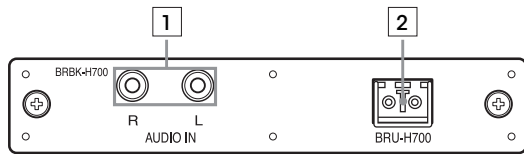

#### 1 AUDIO IN L/R jacks (phono-type)

Input an audio signal (stereo), which is output from the AUDIO OUT jacks on the BRU-H700 HD Optical Multiplex Unit via an optical fiber cable. The time difference between video and audio can be adjusted by up to 240 ms by 10 increments.

**Note** The audio input on this board accepts audio line signals only. When you input audio signals from a microphone or similar device, it should be connected with a microphone amplifier so that audio signals with an appropriate audio level can be input.

#### 2 Optical connector

### 5.3.7 BRBK-HSD1 HD/SD-SDI Output Card

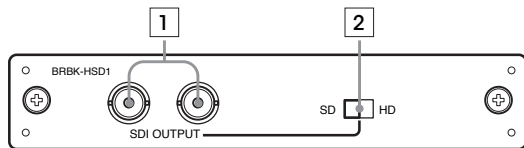

#### 1 SDI OUTPUT connectors (BNC-type)

Supplies down-converted SD-SDI signals that conform to SMPTE259M (for 59.94i signal format) and ITU-R BT.656 (50i signal format) serial digital interface standards, and HD-SDI signals that conform to the SMPTE292M serial digital interface standard. Select HD-SDI or SD-SDI signals with the HD/SD select switch.

#### 2 HD/SD select switch

Set the switch to SD to supply SD-SDI signals and HD to supply HD-SDI signals.

**Note**

- SD-SDI and HD-SDI signals cannot be supplied simultaneously.
- Set the SD/HD select switch before turning on the camera.

### 5.3.8 BRBK-303 Optical Multiplex Card

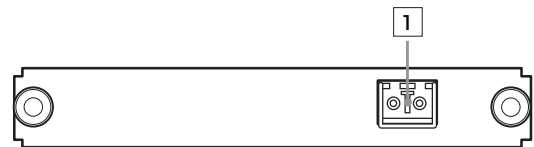

#### 1 Optical connector

### 5.3.9 BRBK-301 Analog RGB Component Card

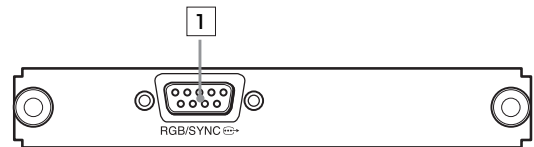

#### 1 RGB/SYNC connector

Pin No.	Signal	Pin No.	Signal
1	GND	6	Composite/Y
2	GND	7	SYNC
3	R/Cr	8	GND
4	G/Y	9	-/C
5	B/Cb		

### 5.3.10 BRBK-302 SDI Card



#### 1 SDI connector

Supplies a signal conforming to the SMPTE259M serial digital interface standard.

### 5.3.11 BRBK-304 DV Card

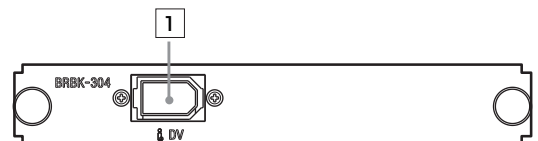

#### 1 i.LINK (DV) OUT connector (i.LINK 6-pin)

# 6

## Basic Set-up and Operation

### 6.1 Connections

These are the basic connections of the cameras and monitor prior to a demonstration.

#### Connections of BRC-H700/BRC-Z700 and monitor

BRC-H700 rear panel with the optional BRBK-H700

Monitor with HD-SDI input

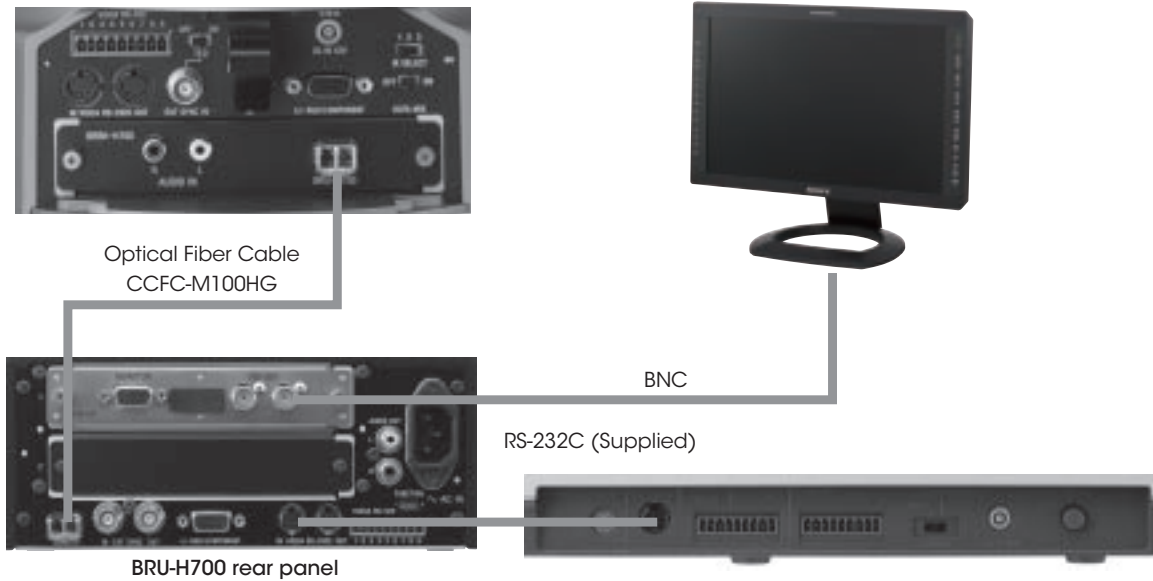

#### Connections of BRC-300/300P and monitor

BRC-300/300P with the optional BRBK-303

Monitor

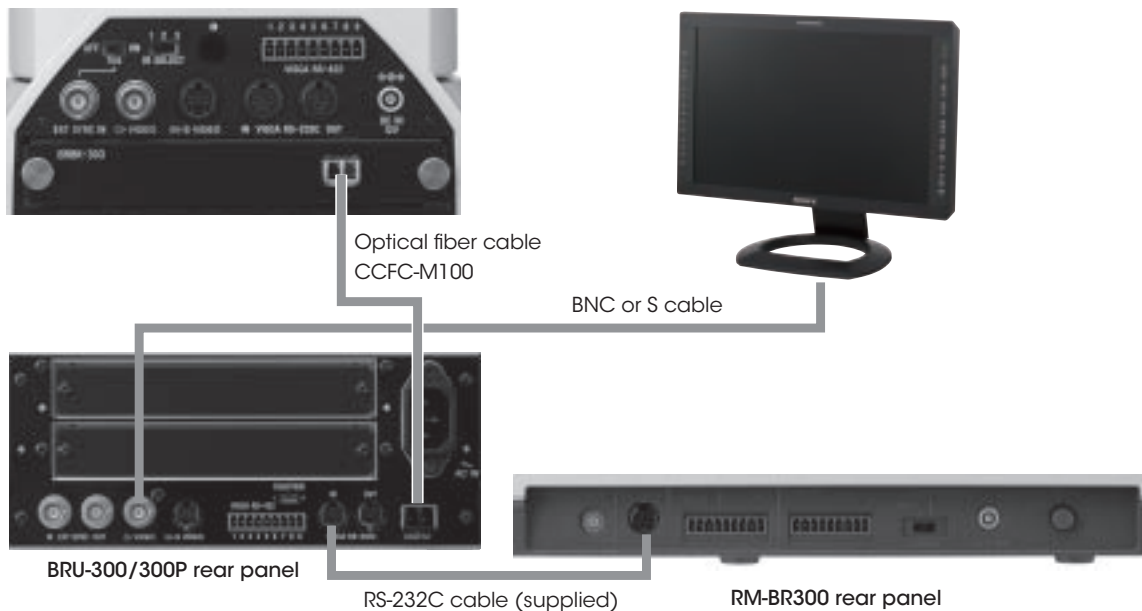

### 6.2 Monitor Set-up

The BRC-H700 and BRC-Z700 come equipped with a Color Bar Output mode, allowing you to precisely adjust the monitor. For the BRC-300/300P, it is suggested that you use the Auto Set-up function.

# 7

## Remote Operation

### 7.1 IR Remote Commander Unit

The following provides information on the function and location of the parts.

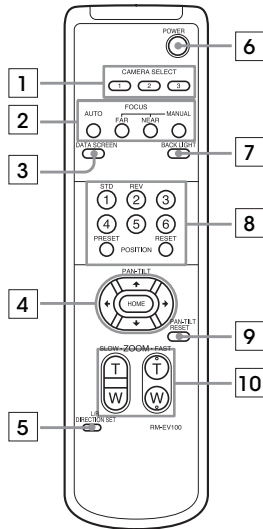

#### 1 CAMERA SELECT buttons

Press the button corresponding to the camera you want to operate with the IR Remote Commander Unit. The camera number can be set using the IR SELECT switch on the rear of the camera.

**Note** If two or more cameras are adjacent and have the same camera number, they are operated simultaneously with the same IR Remote Commander Unit. If you are installing cameras close to each other, make sure you allocate a different camera number to each one.

#### 2 FOCUS buttons

Used for focus adjustment. Press the AUTO button to adjust the focus automatically. To adjust the focus manually, press the MANUAL button, and adjust it with the FAR and NEAR buttons.

#### 3 DATA SCREEN button

Press this button to display the Main menu. Press it again to turn off the menu. If you press the button when a lower-level menu is selected, the display goes back to a higher-level menu.

**Note** Pan/tilt and zoom operations are disabled when the menu is displayed.

#### 4 PAN/TILT buttons

Press the arrow buttons to perform panning and tilting. Press the HOME button to face the camera back to the front. When the menu is displayed, use V or v to select the menu items and B or b to change the set values.

#### 5 L/R DIRECTION SET button

Hold down this button and press the REV button to change camera movement to the opposite direction indicated by the arrow of the B/b buttons. To reset the camera movement direction, press the STD button while holding down this button.

#### 6 POWER switch

Press this button to turn on/off the camera when the camera is connected to an AC outlet.

#### 7 BACK LIGHT button

Press this button to enable the Backlight Compensation function. Press it again to disable Backlight Compensation.

#### 8 POSITION buttons

Hold down the PRESET button and press a number button from 1 to 6 to store the current Camera Direction, Zoom, Focus Adjustment, and Backlight Compensation setting in the memory of the pressed number button. To erase this memory, hold down the RESET button and press the same number button. For the BRC-H700 and BRC-Z700, preset positions from 7 to 16 are not available.

#### 9 PAN/TILT RESET button

Press this button to reset the pan/tilt position.

#### 10 ZOOM buttons

Use the SLOW button to zoom slowly, and the FAST button to zoom quickly. Press the T (telephoto) side of the button to zoom in, and the W (wide angle) side to zoom out.

#### Installing batteries

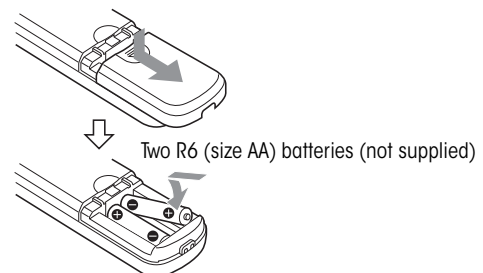

**Caution** To avoid risk of explosion, use R6 (size AA) manganese or alkaline batteries.

## 7.2 RM-BR300 Remote Control Unit

### 7.2.1 Features

#### Effective control of up to seven cameras

The RM-BR300 Remote Control Unit achieves remote operation of up to seven cameras in a daisy-chain configuration, allowing only one operator to manage multiple camera systems.

#### Camera settings

Camera settings such as focus, shutter, iris, and red/blue gain can be adjusted in the menu. In addition, users can select the most appropriate camera mode with the buttons on the front panel.

#### RS-232C/RS-422 Interface

RS-422 cables as well as a supplied RS-232C cable are available to connect the camera to an optical multiplex unit for long-distance operation.

#### Presets of various camera settings

The BRC-H700 and BRC-Z700 each have sixteen presets and the BRC-300/300P has six presets to which pre-defined pan/tilt/zoom positions and other parameters can be allocated.

#### TALLY/CONTACT selector

If you select TALLY on the TALLY/CONTACT selector, you can control the camera selected by the switcher. If you select CONTACT on the TALLY/CONTACT selector, you can operate the camera selected by the RM-BR300 Remote Control Unit. By selecting CONTACT (TALLY) on the TALLY/CONTACT selector, you can control the camera selected by the switcher and also light the camera tally.

#### Improvement achieved with the RM-BR300/4

Model Name	Destination	Serial No.
RM-BR300/4 Remote Control Unit	UC7	110001-
RM-BR300/4 Remote Control Unit	J1	310001-
RM-BR300/4 Remote Control Unit	CE3	410001-

The following features can be achieved with the RM-BR300/4 and after.

#### Improvement of joystick operation (BRC-H700/BRC-Z700/BRC-300/300P)

The pan/tilt speed can be adjusted in seven levels by inclining the joystick to its maximum angle, and pan/tilt operation can be controlled easily at low speed. Only the maximum pan/tilt speed can be set with conventional models.

To select a speed level, hold down the SHIFT button and PAN/TILT RESET button at the same time for a few seconds, and the CAMERA switch lamp on the RM-BR300 starts to flash. Select between 1 and 7: 1 for the lowest speed and 7 is for the highest speed.

#### Addition of Bright Volume Control mode (BRC-H700/BRC-Z700)

Iris can be controlled independently in Bright Volume Control mode, selected with a DIP Switch(3) on the bottom of the RM-BR300/4. Iris and Gain can be adjusted in combination with the previous version of the RM-BR300.

#### Improved Pan/Tilt joystick operation (BRC-Z700)

- Shortens the time lag of the Pan/Tilt joystick.
- Enables fine direction control by the Pan/Tilt joystick.

#### Improved AF operation (BRC-Z700)

While one object is in focus, you can get the next object (Far/Near) into focus by adjusting the Focus Volume (Far/Near), when AF and AF Assist are set to ON.

#### Improved Color Shift operation (BRC-Z700)

R and B can be adjusted separately with R/B Gain Volume when in AWB mode.

#### Improved Focus Volume operation (BRC-Z700)

You can adjust to focus another subject in a forward or backward location with the FOCUS control when AF MODE is AUTO and AF ASSIST is on.



## 7.2.2 Operation

The following information enables easy camera system operation with the benefit of functions such as pan/tilt/zoom operation, preset memory, and more.

**Note** Before operating, check that the camera, the RM-BR300 Remote Control Unit, and peripheral devices are properly installed and connected.

### Turning on the power

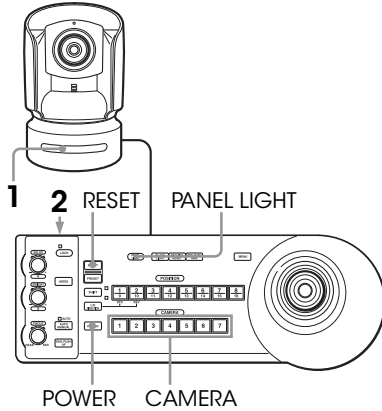

- 1 Connect the camera to an AC outlet using the supplied AC power adaptor and power cord. When the power is turned on, the POWER lamp lights. The camera will automatically pan and tilt, and be reset to the position stored in POSITION 1 (Pan/Tilt Reset action).
- 2 Press the ON/OFF switch on the RM-BR300 Remote Control Unit to turn it on.
- 3 Turn on the peripheral devices.

**Note** Be sure to turn on the power of the camera before the power of the RM-BR300 Remote Control Unit. Otherwise, the RM-BR300 cannot recognize the connected camera.

### To turn on/off the camera using the RM-BR300 Remote Control Unit

While holding down the POWER button, press the CAMERA button corresponding to the required camera. When you turn the power off using the RM-BR300 Remote Control Unit, the POWER lamp turns off and the STANDBY lamp lights on the camera.

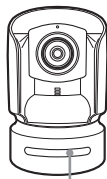

STANDBY lights.

### To illuminate the panel of the RM-BR300 Remote Control Unit

Press the PANEL LIGHT button.



## Operating multiple cameras

To assign camera addresses automatically:

- 1 Make sure that the camera address selector on the bottom of each camera is set to 0.
- 2 Turn on the power of all the connected cameras and the RM-BR300 Remote Control Unit.
- 3 Hold down the RESET button and press the POWER button on the RM-BR300. The RM-BR300 recognizes the connected cameras and assigns them camera addresses, 1 to 7, automatically in the connected order.
- 4 To confirm, press the POWER button on the RM-BR300 and check that the CAMERA buttons light.

### To assign camera addresses manually

Set one of the camera addresses, 1 to 7, using the camera address selectors on the bottom of each camera.

### Camera address selectors

Set the address of the camera. This is normally set to 0. With this setting, addresses are assigned to the cameras automatically in the connected order by pressing the POWER button while holding down the RESET button on the RM-BR300 Remote Control Unit. You can assign the camera address, 1 to 7, manually by setting these selectors as follows:

Camera address	0	1	2	3	4	5	6	7
Switch 1	OFF	ON	OFF	ON	OFF	ON	OFF	ON
Switch 2	OFF	OFF	ON	ON	OFF	OFF	ON	ON
Switch 3	OFF	OFF	OFF	OFF	ON	ON	ON	ON

Switch 4 is not used.

# Pan/tilt/zoom operation

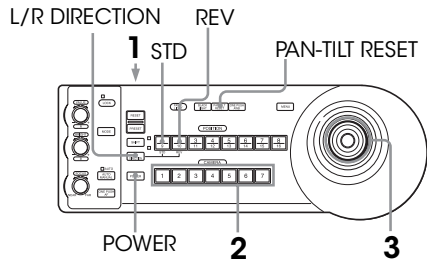

- 1** Press the CAMERA button corresponding to the camera you want to operate.
- 2** Operate the joystick to pan or tilt the camera. While checking the picture on the screen, incline the joystick in the desired direction. The panning/tilting speed changes according to the angle at which you incline the joystick. Release the joystick to stop panning/tilting.

## To return the camera to facing forwards

Press the button on top of the joystick for one or two seconds.

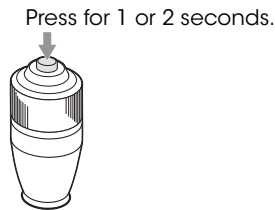

## If you accidentally move the camera with your hand

Press the PAN/TILT RESET button to perform the Pan/Tilt Reset action.

## If the camera moves in a different direction from that you intended

The camera is preset to face towards the right whenever the joystick is inclined to the right. You might wish to face the camera towards a direction that is opposite to the direction you inclined the joystick. For example, you may want to change the direction of the camera while checking the picture on the screen. In this case, press the POSITION 2 (REV) button while holding down the L/R DIRECTION button. To reset the setting, press the POSITION 1 (STD) button while holding down the L/R DIRECTION button.

Joystick	Movement of the camera	Setting
Incline to the right.		While holding down L/R DIRECTION 1 STD Press.
Incline to the right.		While holding down L/R DIRECTION 2 REV Press.

**Note** The setting above only changes the signal emitted from the RM-BR300 Remote Control Unit, and does not change any camera settings.

## If the STANDBY lamp of the camera flashes

When the camera is moved or turned by hand or by external shock, the microcomputer inside the camera may not be able to memorize the pan/tilt position properly. To reset the pan/tilt position, press the PAN/TILT RESET button.

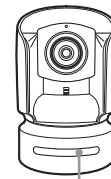

STANDBY flashes.

## Zooming

Turn the dial on the upper part of the joystick.

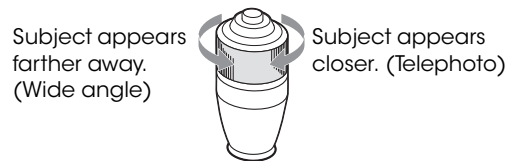

**Note** When you perform a pan/tilt operation with a camera in Telephoto mode, the screen image may move at an uneven speed.

## Adjusting the camera

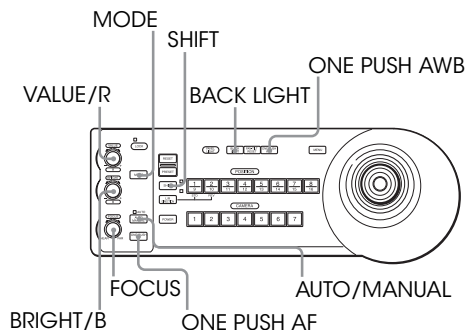

### Focusing on a subject

#### To focus the camera on a subject automatically

Press the AUTO/MANUAL button so that the AUTO Indicator lights.

**Note** The camera focuses on the subject in the center of the screen automatically.



#### To focus the camera on a subject manually

Press the AUTO/MANUAL button so that the MANUAL Indicator lights. Then turn the FOCUS control clockwise or counterclockwise to make the camera focus on the subject.

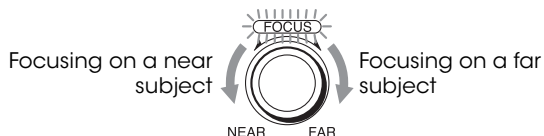

#### One-push auto focusing during manual focus adjustment

Press the ONE PUSH AF button. The camera focuses on the subject in the center of the screen automatically.



### Backlight Compensation function

When you shoot a subject with a light source behind it, press the BACK LIGHT button. To cancel this function, press the BACK LIGHT button again.



**Note** The Backlight Compensation function is not effective if the mode is set to MANUAL in the camera's EXPOSURE menu.

### Spotlight Compensation function

Hold down the SHIFT button and press the BACK LIGHT button. To cancel this function, hold down the SHIFT button and press the BACK LIGHT button again.

**Note** The Backlight and Spotlight Compensation functions cannot be used simultaneously.

### Adjusting the white balance

**Note** Before adjusting the white balance, shoot a white object under the same lighting conditions as the subject you want to shoot, and zoom it in on the screen. (You can use a white wall, etc., instead of the object.)

#### To adjust the white balance automatically

- 1 Set White Balance to ONE PUSH in the camera's COLOR menu.
- 2 Press the ONE PUSH AWB button. The white balance is adjusted automatically.



#### To adjust the white balance manually

- 1 Set White Balance to MANUAL in the camera's COLOR menu.
- 2 Press the MODE button so that the R and B indicators on the VALUE/R and BRIGHT/B controls light (White Balance Adjustment mode).
- 3 Adjust the red gain with the R control and the blue gain with the B control.

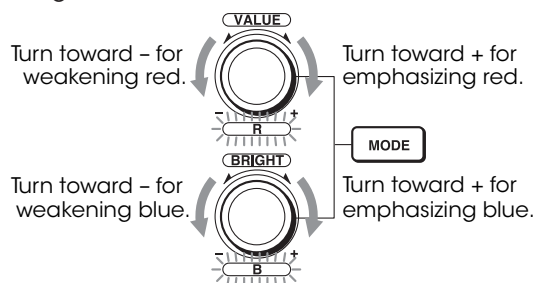

### Functions of the R and B controls

When White Balance Adjustment mode is selected with the MODE button on the RM-BR300 Remote Control Unit, the functions of the R control and B control change according to the White Balance setting in the camera's COLOR menu.

#### BRC-H700

WHITE BALANCE setting	R control	B control
MANUAL	Red gain control	Blue gain control
AUTO, ONE PUSH	WB SHIFT control	WB SHIFT control

#### BRC-Z700

WHITE BALANCE setting	R control	B control
MANUAL	Red gain control	Blue gain control
AUTO 1/2, ONE PUSH	WB R. SHIFT control	WB B. SHIFT control

## Adjusting the brightness

- 1 Set the mode to SHUTTER Pri, IRIS Pri, GAIN Pri, or MANUAL in the camera's EXPOSURE menu.
- 2 Press the MODE button so that the VALUE and BRIGHT indicators on the VALUE/R and BRIGHT/B controls light (Brightness Adjustment mode).
- 3 Adjust the brightness with the VALUE/R or BRIGHT/B control.

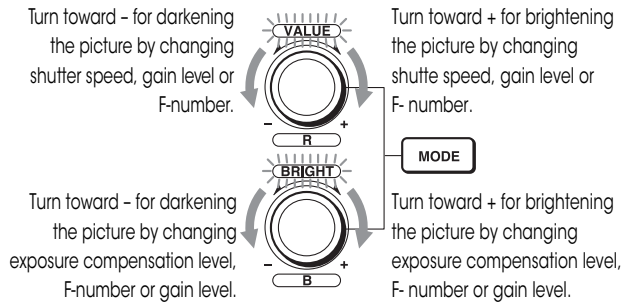

## Functions of the VALUE and BRIGHT controls

The functions of the VALUE control and the BRIGHT control change according to the mode setting in the EXPOSURE menu, as follows:

### BRC-H700

MODE setting	Function of VALUE control	Function of BRIGHT control
FULL AUTO	Not used	Exposure compensation level control*
SHUTTER Priority	Shutter speed control	Exposure compensation level control*
IRIS Priority	F-number control	Exposure compensation level control*
GAIN Priority	Gain control	Not used
MANUAL	Shutter speed control	F-number and gain control

\* When EX-COMP is ON in the EXPOSURE menu.

### BRC-Z700

MODE setting	Function of VALUE control	Function of BRIGHT control
FULL AUTO	Not used	Exposure compensation level control*
SHUTTER Priority	Shutter speed control	Exposure compensation level control*
IRIS Priority	F-number control	Exposure compensation level control*
GAIN Priority	Gain control	Exposure compensation level control*
MANUAL	Shutter speed control	<ul style="list-style-type: none"> <li>•F-number and gain controls (when the DIP switch 3 at the bottom of the Remote Control Unit is set to ON)</li> <li>•F-number control (when the DIP switch 3 at the bottom of the Remote Control Unit is set to OFF)</li> </ul>

\* When EX-COMP is ON in the EXPOSURE menu.

### BRC-300/300P

MODE setting	Function of VALUE control	Function of BRIGHT control
FULL AUTO	Not used	Exposure compensation level control*
SHUTTER Priority	Shutter speed control	Exposure compensation level control*
IRIS Priority	Iris control	Exposure compensation level control*
BRIGHT	Not used	Brightness level control
MANUAL	Shutter speed control	Iris control

\* When EX-COMP is ON in the EXPOSURE menu.

# Storing the Camera Setting in Memory

## Storing camera settings: Memory Preset feature

### To store the camera settings

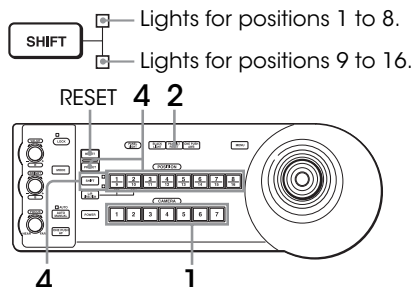

- 1 Press the CAMERA button to select the required camera.
- 2 Press the PAN/TILT RESET button to reset the pan/tilt position.
- 3 Adjust the position, zooming, focusing, and backlighting of the selected camera.
- 4 While holding down the PRESET button (for positions 1 to 8) or the SHIFT and PRESET buttons (for positions 9 to 16), press any of the POSITION buttons in which you want to store settings.

While holding down (for POSITION 1 to 8)

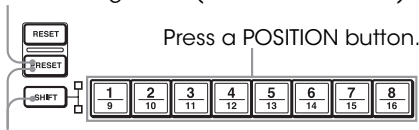

While holding down (for POSITION 9 to 16)

Settings are stored in the memory of the camera. The pressed button flashes during storing. Flashing stops when storing is completed.

### To recall the stored settings

Press any of the POSITION buttons in which you have stored the settings. For positions 9 to 16, hold down the SHIFT button and press any of the POSITION buttons.

### To cancel the preset memory

While holding down the RESET button (for positions 1 to 8) or the SHIFT and RESET buttons (for positions 9 to 16), press the POSITION button from which you want to cancel the settings.

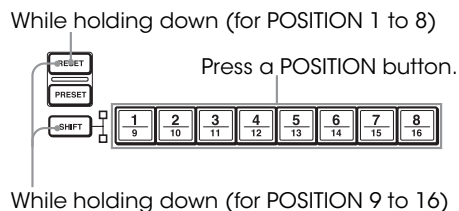

The pressed button flashes while settings are being cancelled. Flashing stops when the settings have been canceled.

#### Note Important note:

- When the power is turned on, the camera starts with the settings stored in POSITION 1.
- If you want to retain the previous pan and tilt position when the power is turned off and turned on again, store those positions in POSITION 1.
- When you are storing or canceling the settings in one position, you cannot call up, store or cancel the settings in another position.

## Setting the speed of the camera moving to a preset position

You can select the panning/tilting speed when the camera moves to a preset position.

- 1 Press the CAMERA button to select the required camera.
- 2 Press the POSITION button for which you want to set the speed for more than one second. All of the CAMERA buttons, 1 to 7, flash.
- 3 Press one of the CAMERA buttons to select the speed.

CAMERA button	Panning/tilting speed
1	1 degree/sec.
2	2.2 degree/sec.
3	4.8 degree/sec.
4	11 degree/sec.
5	23.3 degree/sec.
6	43 degree/sec.
7	60 degrees/sec. (default)

Now the camera will move to the position preset to the pressed POSITION button with the selected speed.

### To set the speed of the camera moving to a preset position between 9 and 16

Hold down the SHIFT button and press the corresponding POSITION button for more than one second. The POSITION 1 to 8 buttons can be used for positions 9 to 16.

## Preset memory

Preset Memory 1: All of the configurations can be stored.

Preset Memory 2 to 16: Frequently-changed configurations can be stored.

Infrequently-changed configurations cannot be stored.

Category Mode/Position		Preset Memory 1		
		BRC-H700	BRC-Z700	BRC-300/300P
Pan/Tilt	Pan/Tilt position	Yes	Yes	Yes
	Pan limit position	Yes	Yes	Yes
	Tilt limit position	Yes	Yes	Yes
	Ramp Curve	Yes	Yes	—
Zoom	Zoom position	Yes	Yes	Yes
	Digital zoom limit	Yes	Yes	Yes
Focus	auto/manual	Yes	Yes	Yes
	normal/interval/ zoom trig	—	—	Yes
	near limit	—	Yes	—
	af assist	—	Yes	—
WB	WB mode	Yes	Yes	Yes
	Auto WB Sense	Yes	Yes	—
	Auto WB Shift	Yes	Yes	—
	One Push WB Shift	Yes	Yes	—
	Manual WB R Gain	Yes	Yes	Yes
Color	Manual WB B Gain	Yes	Yes	Yes
	Gain	Yes	Yes	—
	Hue	Yes	—	—
	Color matrix	—	Yes	—
	R.enhance	—	Yes	—
	G.enhance	—	Yes	—
	B.enhance	—	Yes	—
	YL.enhance	—	Yes	—
CY.enhance	—	Yes	—	
EXPOSURE	MG.enhance	—	Yes	—
	Mode	Yes	Yes	Yes
	AE Speed (Full Auto)	Yes	Yes	—
	AGC limit (Full Auto)	Yes	Yes	—
	Iris limit (Full Auto)	Yes	Yes	—
	Gain (Manual)	Yes	Yes	Yes
	Gain (Gain Priority)	Yes	Yes	—
	Shutter (Manual)	Yes	Yes	Yes
	Shutter (Shutter Priority)	Yes	Yes	Yes
	Iris (Manual)	Yes	Yes	Yes
	Iris (Iris Priority)	Yes	Yes	Yes
	Bright level	—	—	Yes
	Back light	Yes	Yes	Yes
	Spot light	Yes	Yes	—
	Ex-comp mode	Yes	Yes	Yes
	Ex-comp level	Yes	Yes	Yes
	Spot AE	—	—	Yes

Category Mode/Position		Preset Memory 1		
		BRC-H700	BRC-Z700	BRC-300/300P
Picture	Effect Mode	—	—	Yes
	Wide	—	—	Yes
	Aperture (Detail)	Yes	Yes	Yes
	B&W	Yes	Yes	—
	Skintone detail	Yes	—	—
	Gamma	Yes	Yes	—
	Flicker cancel	Yes	Yes	—
	Steady shot	Yes	Yes	—
	Color bar	No	No	—
	Color detail mode	—	Yes <sup>*2</sup>	—
System	Color detail phase	—	Yes	—
	Data mix	—	—	Yes
	Ir receive	Yes	Yes	Yes
	Img flip	Yes	Yes	Yes
	Pan reverse	Yes	Yes	Yes
	Tilt reverse	Yes	Yes	Yes
	Display info	Yes	Yes	Yes
	Analog out	Yes	Yes	—
	Add sync	Yes	Yes	—
	Sync type	Yes	Yes	—
	Sync master	Yes	Yes	—
	H phase	—	Yes	—
	ANALOG OUT <sup>*3</sup>	Output 1	—	—
Sync (Output 1)		—	—	Yes
Output 2		—	—	Yes
DOWN CON- VERTER <sup>*4</sup>	D-Sub out 1	Yes	Yes	—
	Add sync (D-sub out1)	Yes	Yes	—
	D-Sub out 2	Yes	Yes	—
HD-SDI <sup>*5</sup>	Img-size	Yes	Yes	—
	Analog out	Yes	Yes	—
	Sync/vd	Yes	Yes	—
PC- OUTPUT <sup>*6</sup>	Add sync	Yes	Yes	—
	Img size	Yes	Yes	—
	Sync	Yes	Yes	—
HDV <sup>*7</sup>	Vd	Yes	Yes	—
	Audio delay	Yes	Yes	—
SD-SDI <sup>*8</sup>	IMG-SIZE	—	Yes	—

Category Mode/Position		Preset Memory 2 to 16		
		BRC-H700	BRC-Z700	BRC-300/300P
Pan/Tilt	Pan/Tilt position	Yes	Yes	Yes
	Pan limit position	No	No	No
	Tilt limit position	No	No	No
	Ramp Curve	No	No	—
Zoom	Zoom position	Yes	Yes	Yes
	Digital zoom limit	Yes	Yes	Yes
Focus	auto/manual	Yes	Yes	Yes
	normal/interval/ zoom trig	—	—	—
	near limit	—	No	—
	af assist	—	No	—
WB	WB mode	Yes	Yes	Yes
	Auto WB Sense	Yes	Yes	—
	Auto WB Shift	Yes	Yes	—
	One Push WB Shift	Yes	Yes	—
	Manual WB R Gain	Yes	Yes	Yes
	Manual WB B Gain	Yes	Yes	Yes
Color	Gain	Yes	Yes	—
	Hue	Yes	—	—
	Color matrix	—	Yes	—
	R.enhance	—	Yes	—
	G.enhance	—	Yes	—
	B.enhance	—	Yes	—
	YL.enhance	—	Yes	—
	CY.enhance	—	Yes	—
EXPOSURE	MG.enhance	—	Yes	—
	Mode	Yes	Yes	Yes
	AE Speed (Full Auto)	Yes	Yes	—
	AGC limit (Full Auto)	Yes	Yes	—
	Iris limit (Full Auto)	Yes	Yes	—
	Gain (Manual)	Yes	Yes	Yes
	Gain (Gain Priority)	Yes	Yes	—
	Shutter (Manual)	Yes	Yes	Yes
	Shutter (Shutter Priority)	Yes	Yes	Yes
	Iris (Manual)	Yes	Yes	Yes
	Iris (Iris Priority)	Yes	Yes	Yes
	Bright level	—	—	Yes
	Back light	Yes	Yes	Yes
	Spot light	Yes	Yes	—
	Ex-comp mode	Yes	Yes	Yes
	Ex-comp level	Yes	Yes	Yes
	Spot AE	—	—	No

Category Mode/Position		Preset Memory 2 to 16			
		BRC-H700	BRC-Z700	BRC-300/300P	
Picture	Effect Mode	—	—	No	
	Wide	—	—	No	
	Aperture (Detail)	Yes	Yes	Yes	
	B&W	Yes	Yes	—	
	Skintone detail	Yes	—	—	
	Gamma	Yes	Yes	—	
	Flicker cancel	Yes	Yes	—	
	Steady shot	Yes	Yes	—	
	Color bar	No	No	—	
	Color detail mode	—	Yes <sup>*2</sup>	—	
	Color detail phase	—	Yes	—	
	System	Data mix	—	—	No
		Ir receive	No	No	No
		Img flip	No	No	No
Pan reverse		No	No	No	
Tilt reverse		No	No	No	
Display info		No	No	No	
Analog out		No	No	—	
Add sync		No	No	—	
Sync type		No	No	—	
Sync master		No	No	—	
ANALOG OUT <sup>*3</sup>	H phase	—	No	—	
	Output 1	—	—	No	
	Sync (Output 1)	—	—	No	
DOWN CON- VERTER <sup>*4</sup>	Output 2	—	—	No	
	D-Sub out 1	No	No	—	
	Add sync (D-sub out1)	No	No	—	
	D-Sub out 2	No	No	—	
HD-SDI <sup>*5</sup>	Img-size	No	No	—	
	Analog out	No	No	—	
	Sync/vd	No	No	—	
PC- OUTPUT <sup>*6</sup>	Add sync	No	No	—	
	Img size	No	No	—	
	Sync	No	No	—	
HDV <sup>*7</sup>	Vd	No	No	—	
	Audio delay	No	No	—	
SD-SDI <sup>*8</sup>	IMG-SIZE	—	No	—	

**Note** \*1: For the BRC-300, the preset memories from 7 to 16 are not available.

\*2: You cannot save 'CHECK' in color detail mode.

\*3: This function is available when BRBK-301 is inserted to the BRC-300/300P.

\*4: This function is available when HFBK-SD1 is inserted to the BRC-H700 or the BRU-H700.

\*5: This function is available when HFBK-HD1 is inserted to the BRC-H700 or the BRU-H700.

\*6: This function is available when HFBK-XG1 is inserted to the BRC-H700 or the BRU-H700.

\*7: This function is available when HFBK-TS1 is inserted to the BRC-H700 or the BRU-H700.

\*8: This function is available when using the BRBK-HSD1 and the optional video card's HD/SD switch is set to SD side.

# 8

## Operation with the AWS-G500/G500HD Anycast Station

The BRC Series can be remotely controlled by the AWS-G500/G500HD Anycast Station.

### 8.1 Controlling cameras with the AWS-G500/G500HD Anycast Station

You can set and select a maximum of six camera presets, such as the Pan, Tilt, Zoom, and Focus settings, and more. For the BRC-H700 and BRC-Z700, preset positions from 7 to 16 are not available.

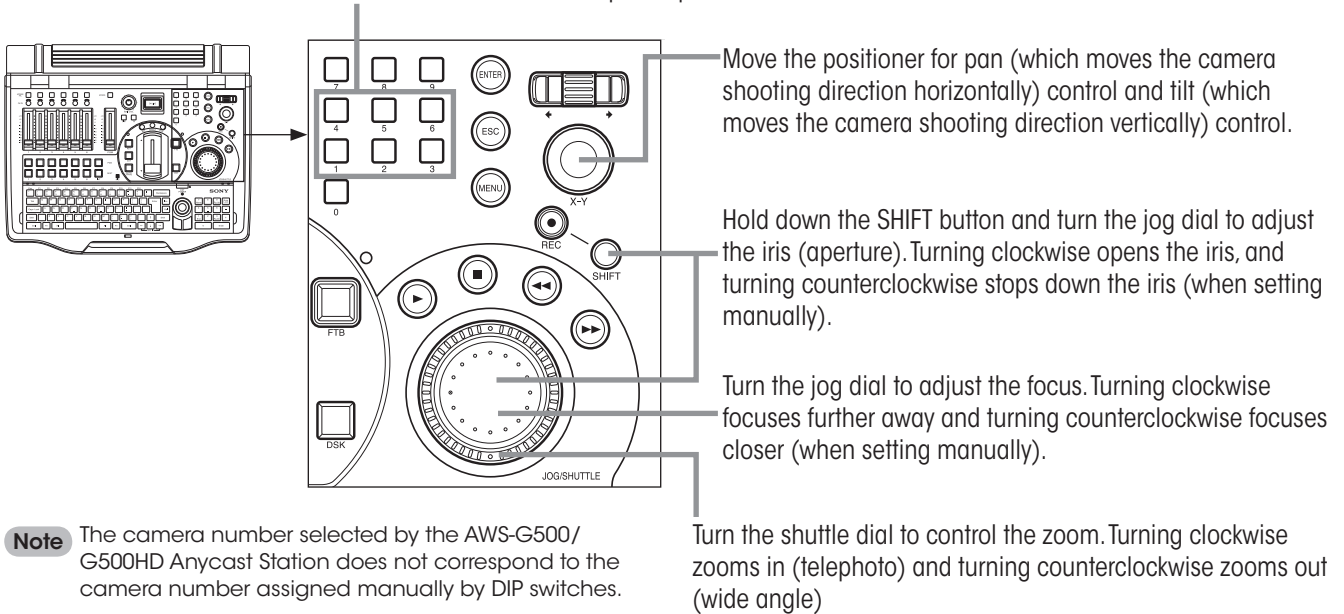

### Live Event Venue with Dual Screen

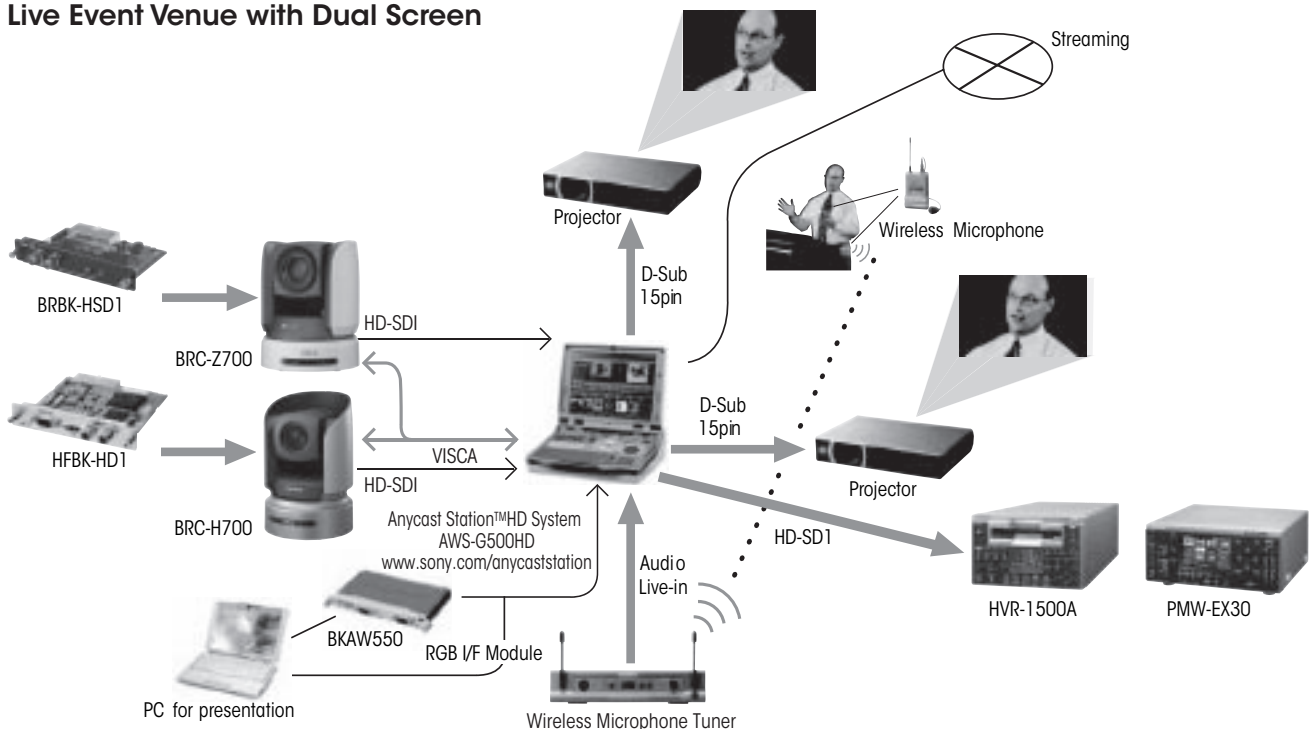

For more detailed information, please refer to the operation manual of the AWS-G500/G500HD.



## System Configuration

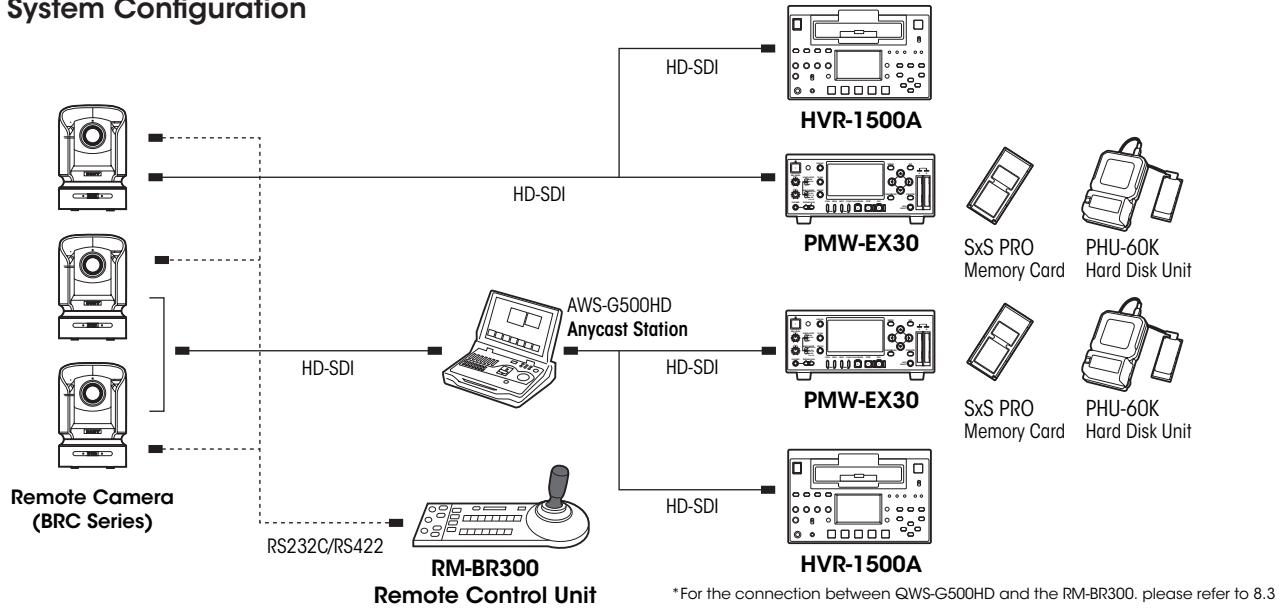

## 8.2 Controlling the camera with VISCA support

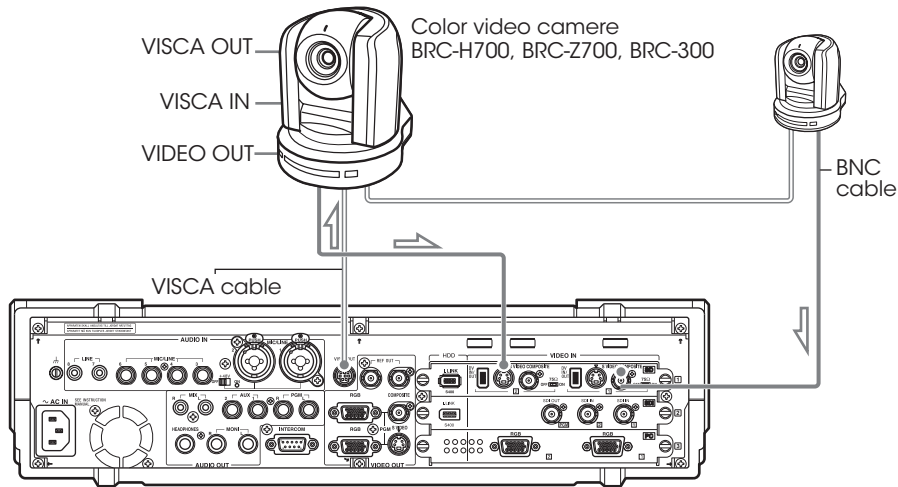

**Note** When connecting a BRC-300/300P camera, connect to the DV, RGB, and SDI input connectors in accordance with the camera's option board.

### When an HD Video Interface module is Connected (BRC-H700, BRC-Z700)

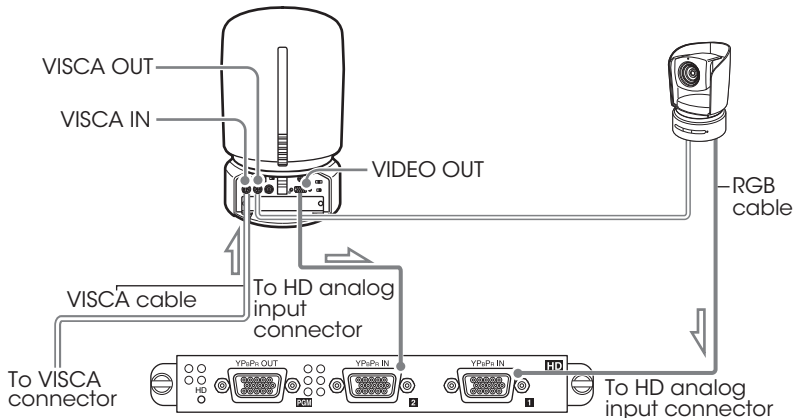

**Note**

- VISCA cables up to 15 m (50 ft) are recommended to operate correctly.
- When connecting a BRC-H700/BRC-Z700 camera, connect to the RGB, SDI, and HD analog input connectors in accordance with the camera's option board.

## 8.3 Operating the PGM and NEXT Selection buttons from the RM-BR300

When you connect the RM-BR300 to the FACTORY USE connector on the unit, you can perform switching for the PGM and NEXT selection buttons from the RM-BR300. Refer to the following diagram to prepare the cables.

### Sample Circuit diagram

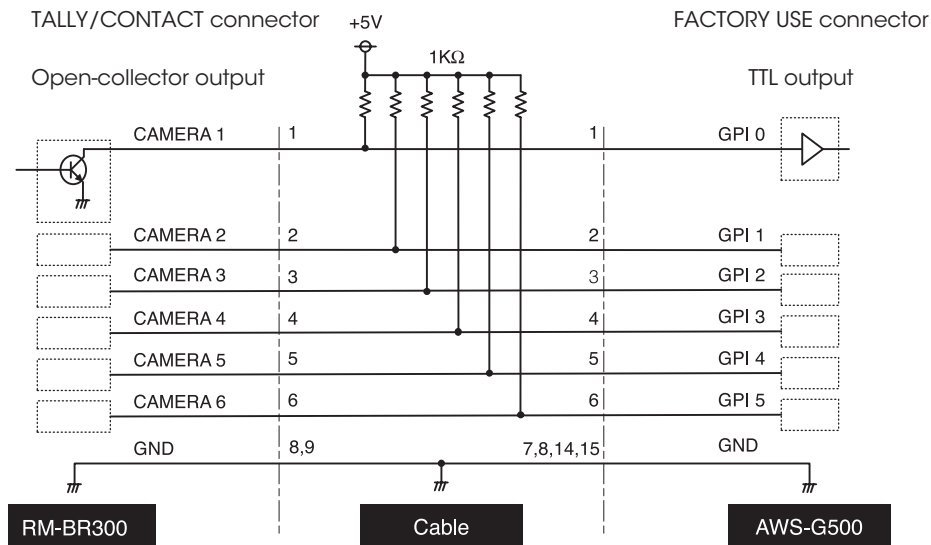

For details on other device models, please contact to the regional headquarters.

- Caution**
- Pull-up of all signal lines is necessary.
  - Set TRIGGER to LOW LEVEL (this section is made in Remote Switching in the Video utility)
  - On the RM-BR300, set the TALLY/CONTACT switch to CONTACT.

- 1 Connect the RM-BR300 to the FACTORY USE connector.
- 2 Press the MENU button.
- 3 In the top menu, select [Video Utility]
- 4 (1) select [Remote Switching], and confirm;  
(2) select the buttons to be controlled by the RM-BR300, and confirm.

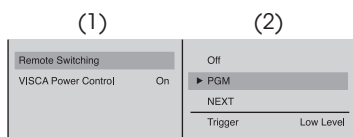

The functions of the setting items are as follows.

- [Off]: Disables switching from the RM-BR300.
- [PGM]: Enables switching operations for PGM selection buttons 1 to 6 from the RM-BR300.
- [NEXT]: Enables switching operations for NEXT selection buttons 1 to 6 from the RM-BR300. Use this to perform VISCA camera control. When the KEY button is lit, you can make key source selections.

- Caution** Connect the RM-BR300 before configuring this setting.

- Note** When [Remote Switching] is enabled, the following icon appears. Example: When [PGM] is selected.



- 5 (1) Select [Trigger], and confirm;  
(2) select an input level, and confirm.

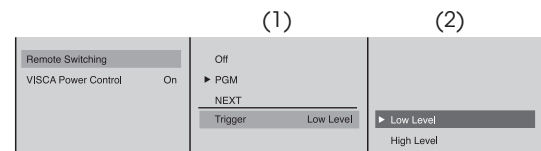

- The functions of the setting items are as follows.
- [Low Level]: Triggers remote switching when input levels become low.
  - [High Level]: Triggers remote switching when input levels become high.

- 6 Press the MENU button to close the menu.

# 9

## Using the BRC-H700/BRC-Z700 as a Second Camera for the PCS-XG80 Video Conferencing System

### Using the BRC-H700 or the BRC-Z700 as a Second Camera for the PCS-XG80 Video Conferencing System

You can connect the BRC-H700 or the BRC-Z700 through the PCS-XG80 Camera Unit.

### Connection example for a second camera

Connect the video output connector on the BRC-H700 or the BRC-Z700 to the VIDEOIN YPbPr jacks on the front of the Communication System.

Select "YPbPr" in "Second Camera Input" of the Camera setup menu.

### To switch the picture shot by two cameras

When the camera input selection is available, the instruction "F2: Switches to the first camera." Or "F2: Switches to the second camera." is displayed at the bottom of the monitor screen. Each press of the F2 button on the Remote commander changes the picture shot by each camera.

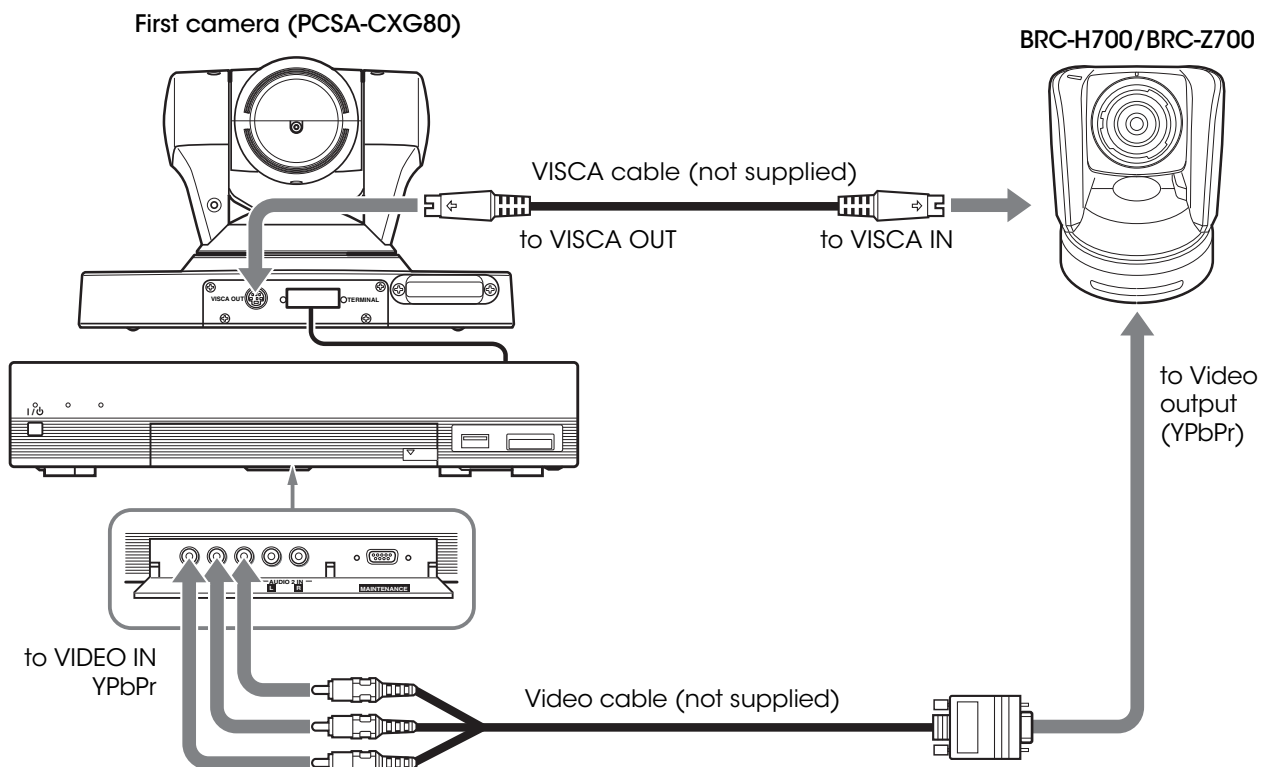

# 10

## Specifications

	BRC-H700	BRC-Z700	BRC-300	BRC-300P
<b>Camera</b>				
Signal systems	1080/59.94i or 1080/50i (switchable)	1080/59.94i, NTSC or 1080/50i, PAL (switchable)	NTSC	PAL
Sync systems	Internal/External			
Image device	1/3-type IT CCD x 3	1/4-type CMOS x 3	1/4.7-type CCD x 3	
Total picture elements	Approx. 1.12 Megapixels		Approx. 1.07 Megapixels	
Effective picture elements	Approx. 1.07 Megapixels	Approx. 1.04 Megapixels	Approx. 0.69 Megapixels	
Lens	12x optical zoom (48x with digital zoom), Carl Zeiss Vario-Sonnar T* lens	20x optical zoom (80x with digital zoom), Carl Zeiss Vario-Sonnar T* lens	12x optical zoom (48x with digital zoom)	
Focal length	f=4.5 to 54 mm (F1.6 to F2.8)	f=3.9 to 78 mm (F1.6 to F2.8)	f=3.6 to 43.2 mm (F1.6 to F2.8)	
Lens filter diameter	72 mm	62 mm	37 mm	
Minimum object distance	500 mm (Wide), 800 mm (Tele)	10 mm (Wide, Limiter Off), 500 mm (Wide, Limiter On), 800 mm (Tele)	300 mm (Wide), 800 mm (Tele)	
Horizontal viewing angle	5.5 to 60.3 degrees	3.0 to 55.2 degrees	4:3 mode: 3.3 to 37.8 degrees, 16:9 mode: 4.0 to 45.4 degrees	
Focusing system	Auto/Manual			
Pan/Tilt angle	-170 to +170 degrees (Pan), -30 to +90 degrees (Tilt)			
Pan/Tilt speed	0.25 to 60 degrees/s (Pan/Tilt)	0.22 to 60 degrees/s (Pan/Tilt)	0.25 to 60 degrees/s (Pan/Tilt)	
Minimum illumination	6 lx (50 IRE, F1.6, +18 dB)	6 lx (50 IRE, F1.6, +24 dB)	7 lx (25 IRE, F1.6, +18 dB)	
Video S/N ratio	50 dB			
Shutter speed	1/10,000 to 1/60 s or 1/10,000 to 1/50 s		1/10,000 to 1/4 s	1/10,000 to 1/3 s
Gain	Auto/Manual (0 to 18 dB and Hyper Gain)	Auto/Manual (0 to 24 dB and Hyper Gain)	Auto/Manual (-3 to 18 dB)	
White balance	Auto/Indoor/Outdoor/One-push/Manual	Auto1/Auto2/Indoor/Outdoor/One-push/Manual	Auto/Indoor/Outdoor/One-push/Manual	
Image stabilizer	On/Off (Optical)		-	
Image flip	On/Off			
ND filter	ND1/ND2/Off	-		
Preset positions	16		6	
<b>Interfaces</b>				
HD video output	D-Sub 15 pin: Component (Y/Pb/Pr) or RGB, HD, VD or SYNC		-	
SD video output	-	BNC: Composite, Mini DIN 4 pin : Y/C	BNC: Composite (NTSC), Mini DIN 4 pin: Y/C	BNC: Composite (PAL), Mini DIN 4 pin : Y/C
External Sync input	BNC			
Camera control	Mini DIN 8 pin: RS-232C (VISCA IN), Mini DIN 8 pin: RS-232C (VISCA OUT), Connector plug 9 pin: RS-422 (VISCA IN/OUT)			
<b>General</b>				
Operating temperature	0 to 40 degrees (32 to 104 °F)			
Storage temperature	-20 to 60 degrees (-4 to 140 °F)			
Power requirements	DC 10.8 to 13.2 V			
Power consumption	Max. 24 W (without optional cards)	Max 28.8 W (without optional cards)	Max. 21.6 W (without optional cards)	
Dimensions (W x H x D)	207 x 310.8 x 207 mm (8 1/4 x 12 1/4 x 8 1/4 inches)	198 x 247 x 238 mm (7 7/8 x 9 3/4 x 9 3/8 inches)	180 x 210.1 x 205 mm (7 1/8 x 8 3/8 x 8 1/8 inches)	
Mass	4.5 kg (9 lb 15 oz)		2.5 kg (5 lb 8 oz)	
Supplied accessories	IR Remote Commander Unit, AC power adaptor, AC power cord, RS-422 connector plug, Ceiling bracket x2, Wire rope, Screws, Operating instructions			

	BRU-H700	BRU-300	BRU-300P
<b>Interfaces</b>			
Optical fiber connector	LC Duplex Fiber Connector		
HD video output	D-Sub 15 pin: Component (Y/Pb/Pr) or RGB, HD, VD or SYNC	–	
SD video output	–	BNC: Composite (NTSC), Mini DIN 4 pin: Y/C	BNC: Composite (PAL), Mini DIN 4 pin: Y/C
External sync input	BNC		
External sync output	BNC		
Audio line output	Phono jack x2 (L/R)	–	
Camera control	Mini DIN 8 pin: RS-232C (VISCA IN), Mini DIN 8 pin: RS-232C (VISCA OUT), Connector plug 9 pin: RS-422 (VISCA IN/OUT)		
Optional card slots	2 slots	2 slots (When both slots are used simultaneously, the interface cards must be of two different types.)	
<b>General</b>			
Operating temperature	0 to 40 degrees (32 to 104 °F)		
Storage temperature	-20 to 60 degrees (-4 to 140 °F)		
Power requirements	AC 100 to 240 V (50/60 Hz)		
Power consumption	Max. 10 W (without optional cards)	Max. 9 W (without optional cards)	
Dimensions (W x H x D)	210 x 86 x 240 mm (8 3/8 x 3 1/2 x 9 1/2 inches)	212 x 88 x 210 mm (8 3/8 x 3 1/2 x 8 3/8 inches)	
Mass	2.4 kg (5 lb 5 oz)	2.1 kg (4 lb 10 oz)	
Supplied accessories	AC power cord, RS-422 connector plug, RS-232C cable (3 m, Mini DIN 8 pin), Operating instructions		

	HFBK-HD1	HFBK-SD1	HFBK-XG1	HFBK-TS1
Video output	D-Sub 15 pin: Component (Y/Pb/Pr) or RGB, HD, VD or SYNC BNC x2: HD-SDI	D-Sub 9 pin: Component (Y/Pb/Pr) or RGB, Composite or Y/C, SYNC BNC: Composite BNC: SD-SDI	D-Sub 15 pin: RGB, HD, VD (WXGA/XGA/VGA)	i.LINK 6 pin: HDV OUT (IEEE1394 S100)
Audio line input				Phono jack x2 (L/R)

	BRBK-HSD1	BRBK-301	BRBK-302	BRBK-304
Video output	BNC x2: HD-SDI or SD-SDI	D-Sub 9 pin: Component (Y/Pb/Pr) or RGB, Composite or Y/C, SYNC	BNC: SD-SDI	i.LINK 6 pin: DV OUT (IEEE1394 S100)

# 11

## Dimensions

### BRC-H700

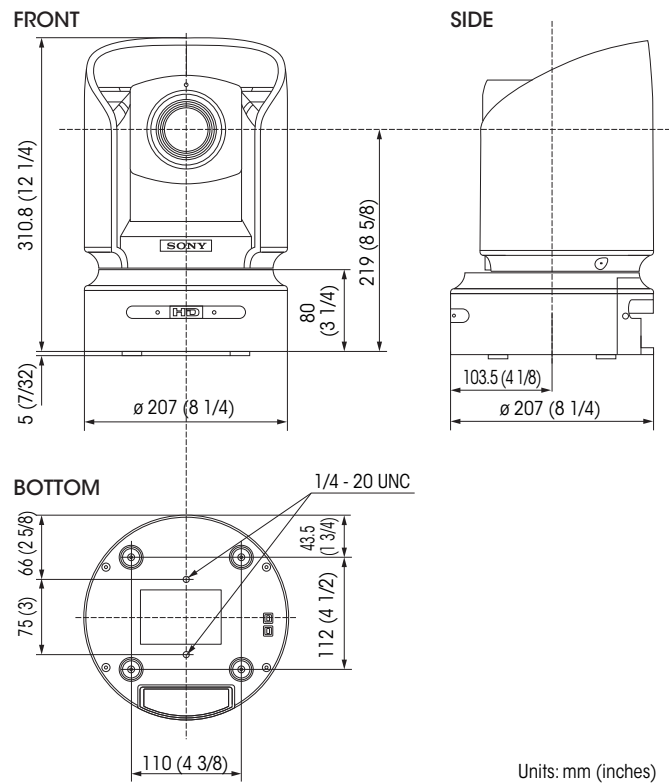

### BRC-Z700

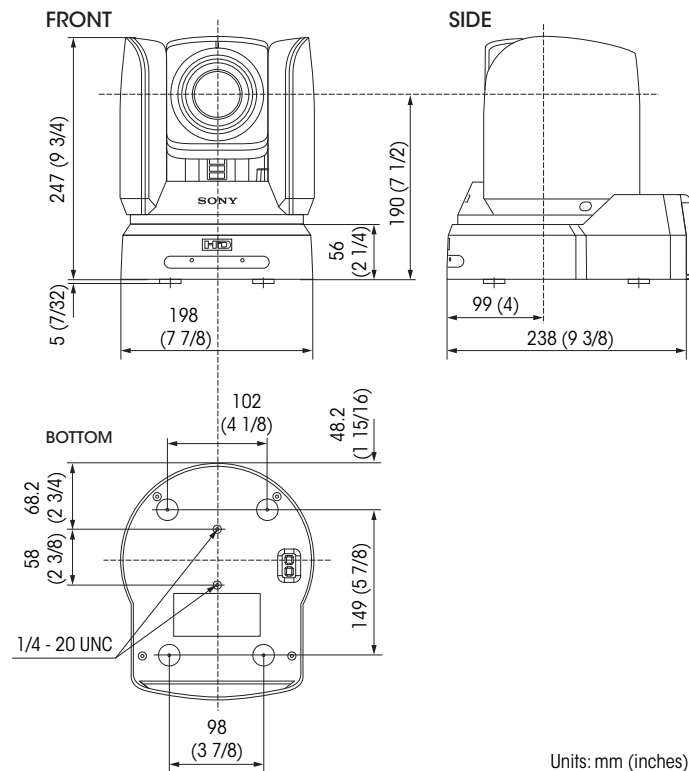

## BRC-300/300P

FRONT

SIDE

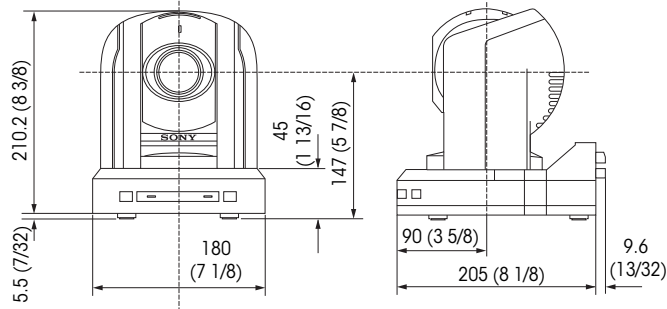

BOTTOM

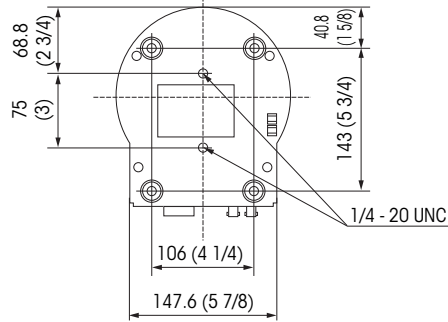

Units: mm (inches)

## RM-BR300

Top

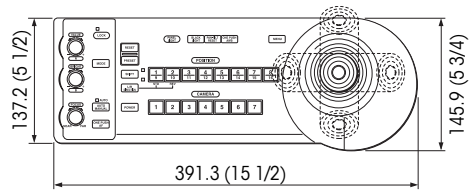

Front

Side

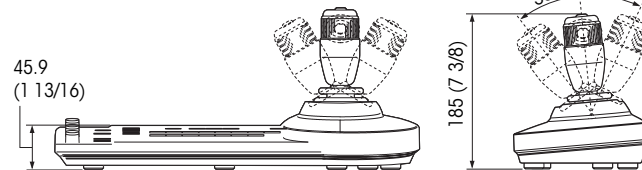

Bottom

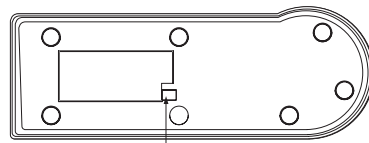

DIP switches

Units: mm (inches)

Rear

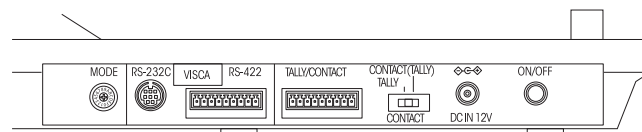

## BRU-H700

Top

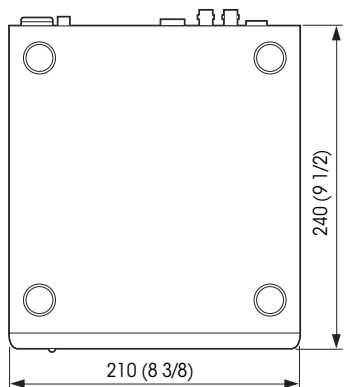

Side



Front

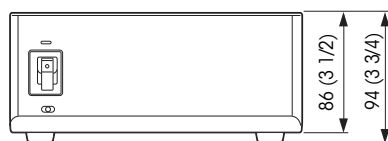

Units: mm (inches)

## BRU-300/300P

Top

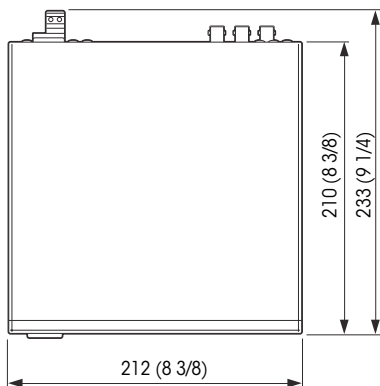

Side

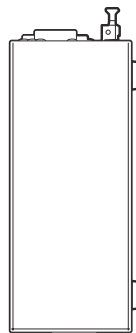

Front



Units: mm (inches)



### Ceiling Bracket (B) for BRC-H700

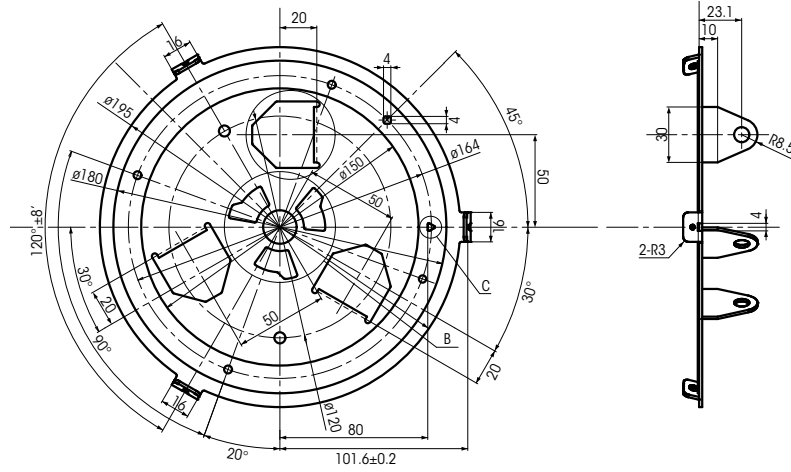

### Ceiling Bracket (B) for BRC-Z700

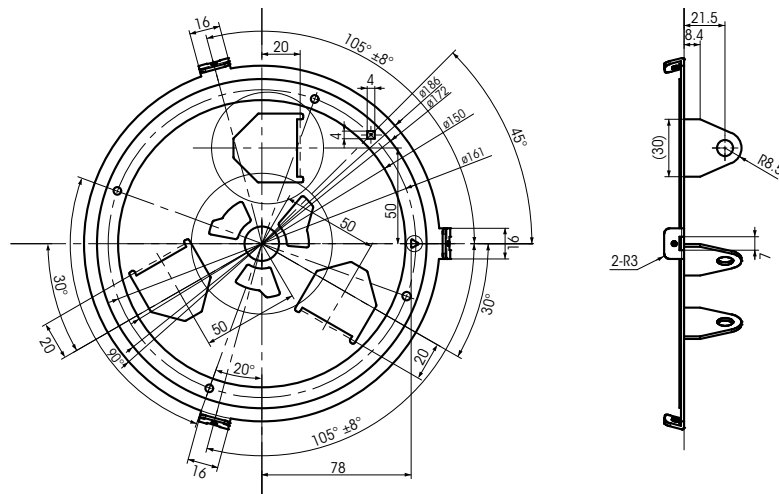

### Ceiling Bracket (B) for BRC-300/300P

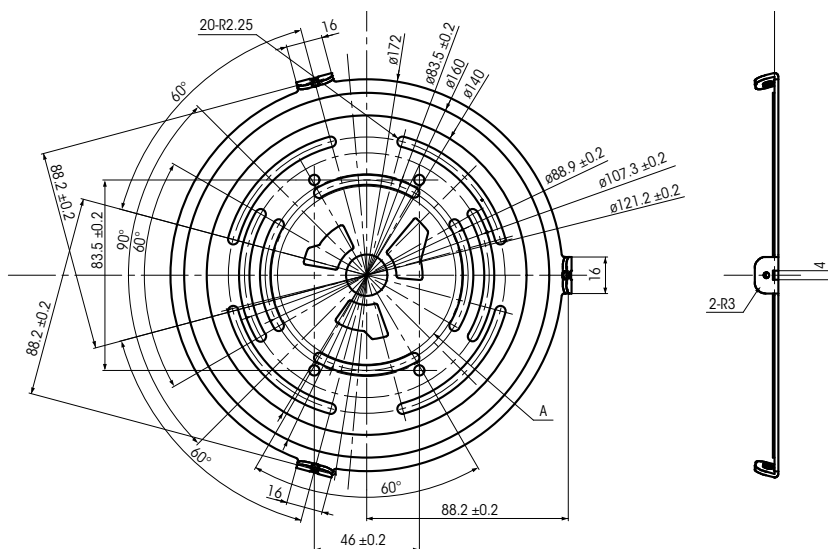

# 12 Technical Appendix

## 12.1 Color Adjustment (BRC-H700, BRC-Z700)

BRC-Z700 achieves enhancing or reducing of a specific color region without changing the white balance focusing point. The camera adjusts saturation of six colors independently, as shown in the diagram. The BRC-H700 is able to modulate six colors all at once.

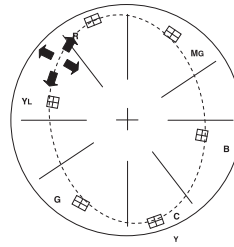

Color gain & hue (BRC-H700)

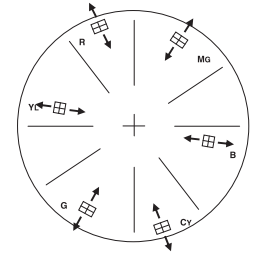

Color matrix (BRC-Z700)

## 12.2 Color Detail (BRC-Z700)

BRC-Z700 reduces the image enhancer of a specific color, which is a great improvement from a conventional skin tone detail function. Therefore, you can adjust size of all color as well as the size of skin tone color.

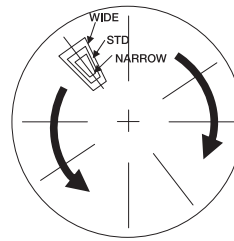

# 12.3 Estimated Viewing Angle of BRC Sereis

## Estimated Viewing Angle (width)

### BRC-H700 Wide-end

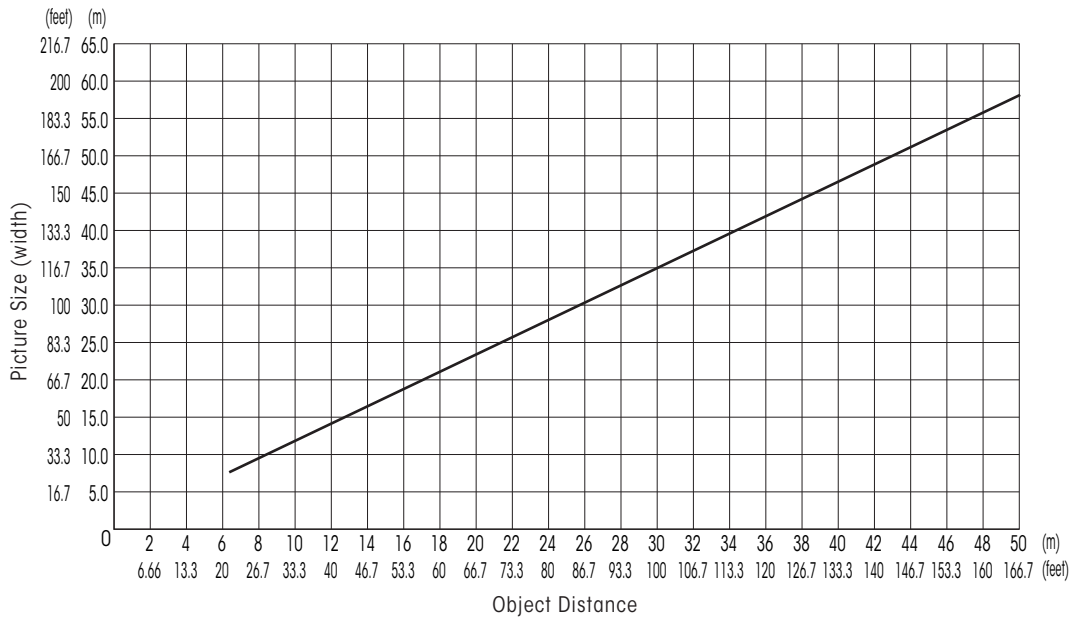

### BRC-H700 Tele-end

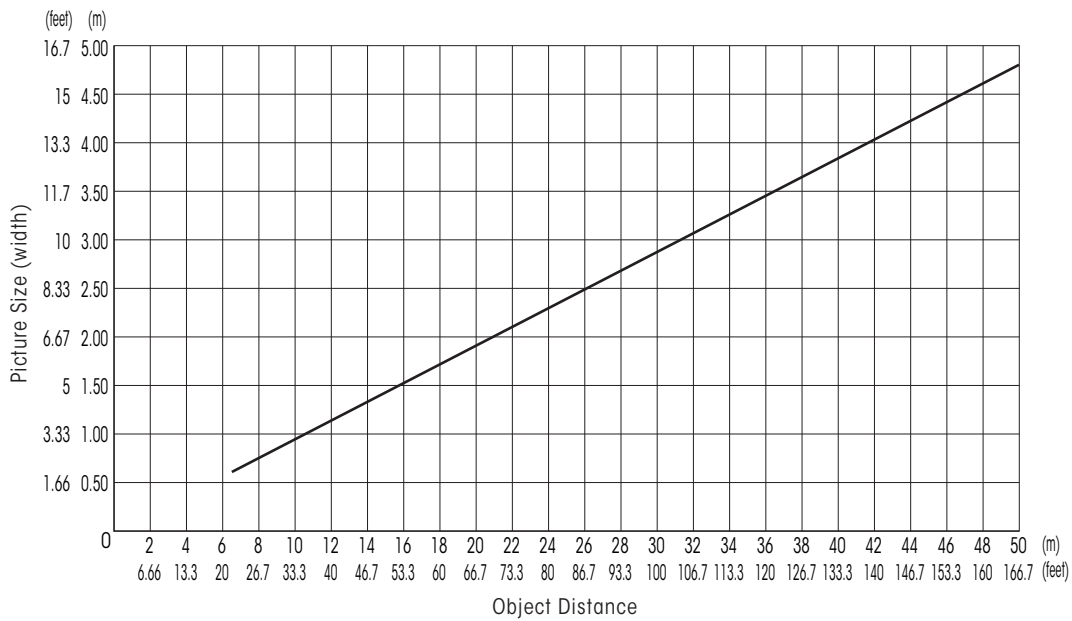

# Estimated Viewing Angle (width)

## BRC-Z700 Wide-end



## BRC-Z700 Tele-end

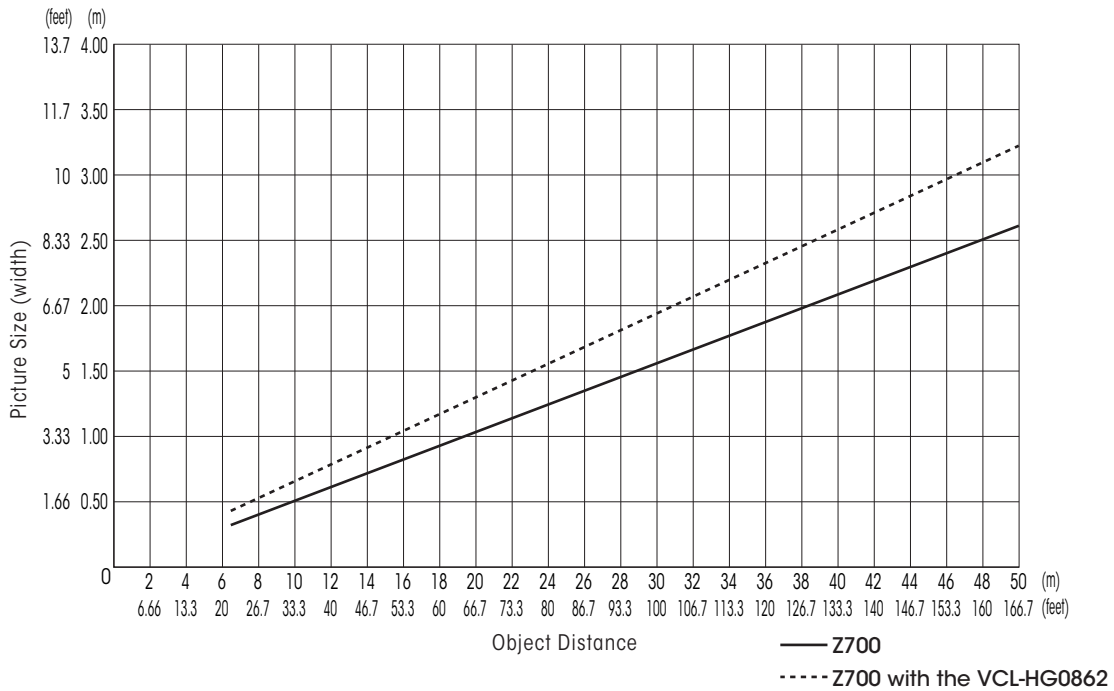

## Estimated Viewing Angle (width)

### BRC-300/300P Wide-end (16:9 mode)

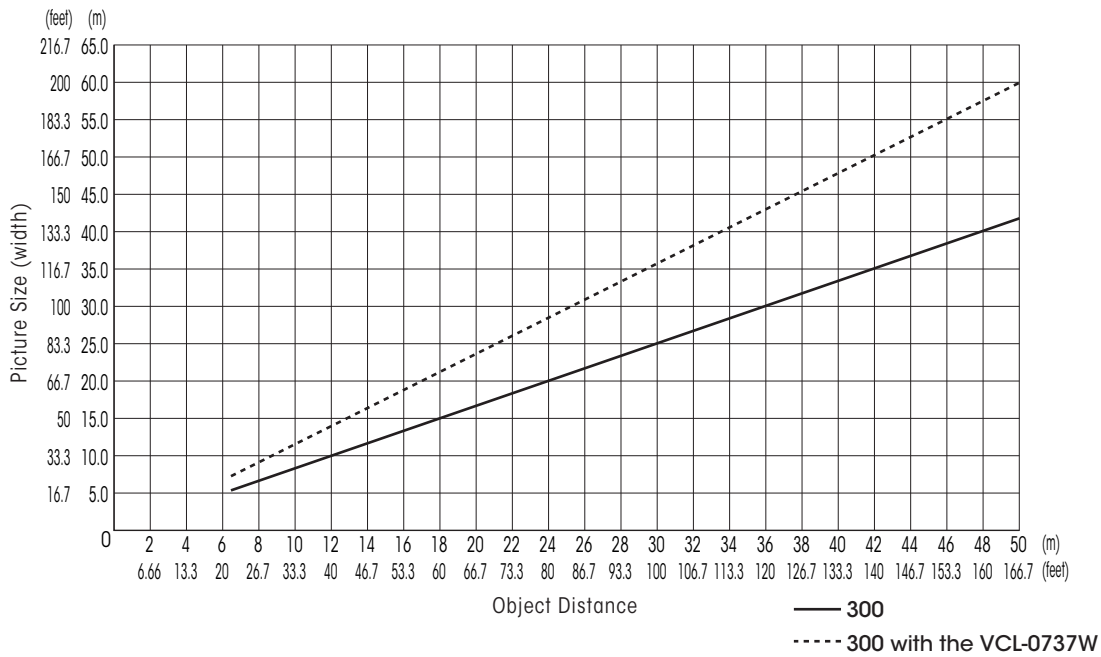

### BRC-300/300P Tele-end (16:9 mode)

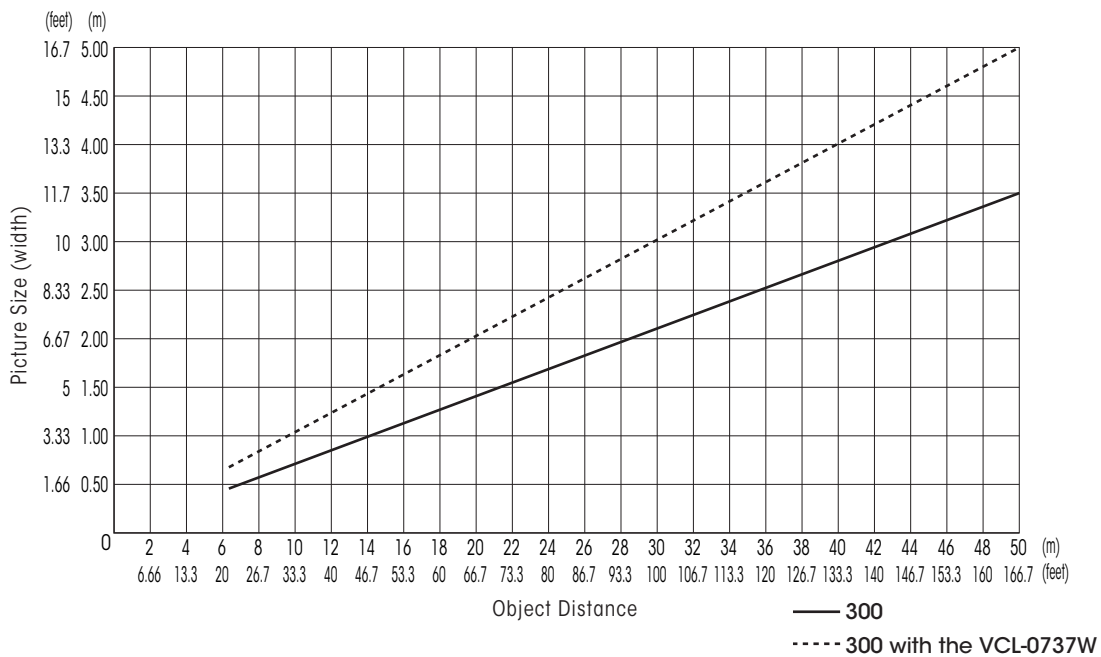

# Estimated Viewing Angle (width)

## BRC-300/300P Wide-end (4:3 mode)

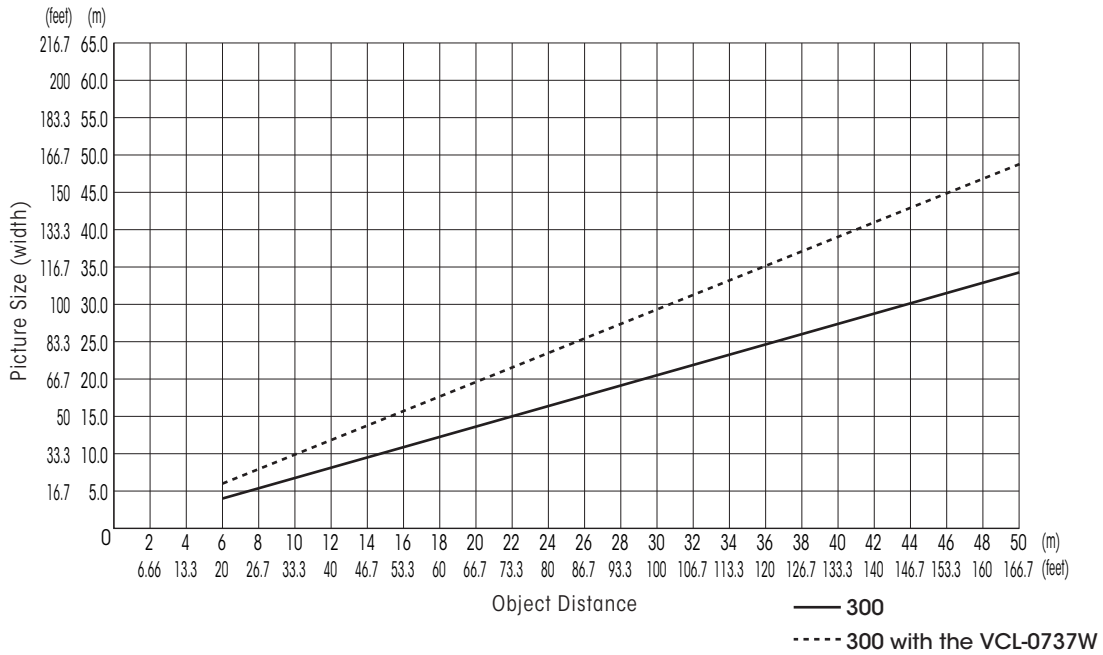

## BRC-300/300P Tele-end (4:3 mode)

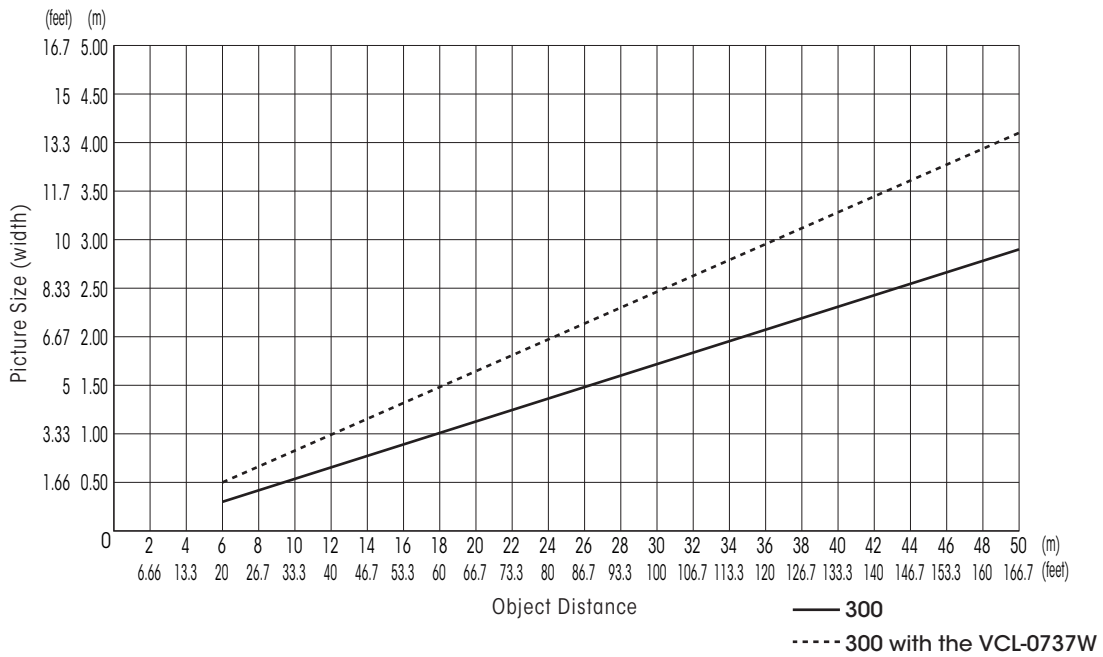

## 12.4 Sync Lock Setting

In order to match output signal timing to the input signal, the Sync Master setting is required on the Main menu. To achieve this, select Menu, System, and then Sync Master.

### BRC-H700

Output signal to be matched with input signal

- When using HFBK-HD1 [ HD1 ]
- When using HFBK-SD1 [ SD1 ]
- Output from main unit BRC-H700 [ STD ]

### BRC-Z700

When HD output signal from BRC-Z700 main unit [STD [HD]]

When SD output signal from BRC-Z700 main unit [STD [SD]]

When connecting with BRU-H700

Output signal from BRU-H700 [STD [HD]]

When using HFBK-HD1 with BRU-H700 [ HD1 ]

When using HFBK-SD1 with BRU-H700 [SD1]

## 12.5 Recommended Lighting Conditions

The BRC-H700: brighter than 400 lx

The BRC-Z700: brighter than 450 lx

The BRC-300/300P: brighter than 600 lx

## 12.6 Using the VISCA RS-422 Connector Plug

- 1 Insert a wire (AWG Nos. 28 to 18) into the desired wire opening on the VISCA RS-422 connector plug, and tighten the screw for that wire using a flathead screwdriver.

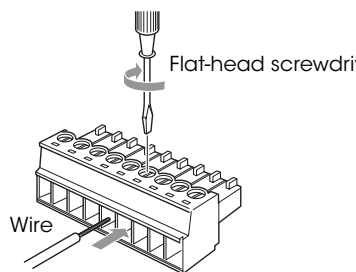

- 2 Insert the VISCA RS-422 connector plug into the VISCA RS-422 connector.

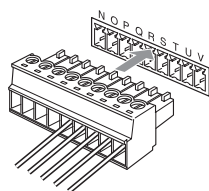

### To remove the connector plug

Grasp both ends of the VISCA RS-422 connector plug and pull it out as shown in the illustration.

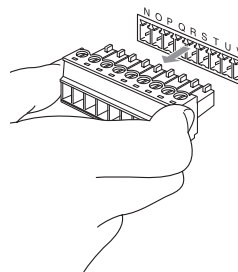

- Note**
- In order to stabilize the voltage level of the signal, connect both ends to GND.
  - When you make connections using VISCA RS-422 connectors, the VISCA RS-232C connection is not available.
  - The maximum connection distance with VISCA RS-422 connection is approximately 1,200 m (3,937 ft).

# 12.7 Wiring Diagram of VISCA RS-422 Connection

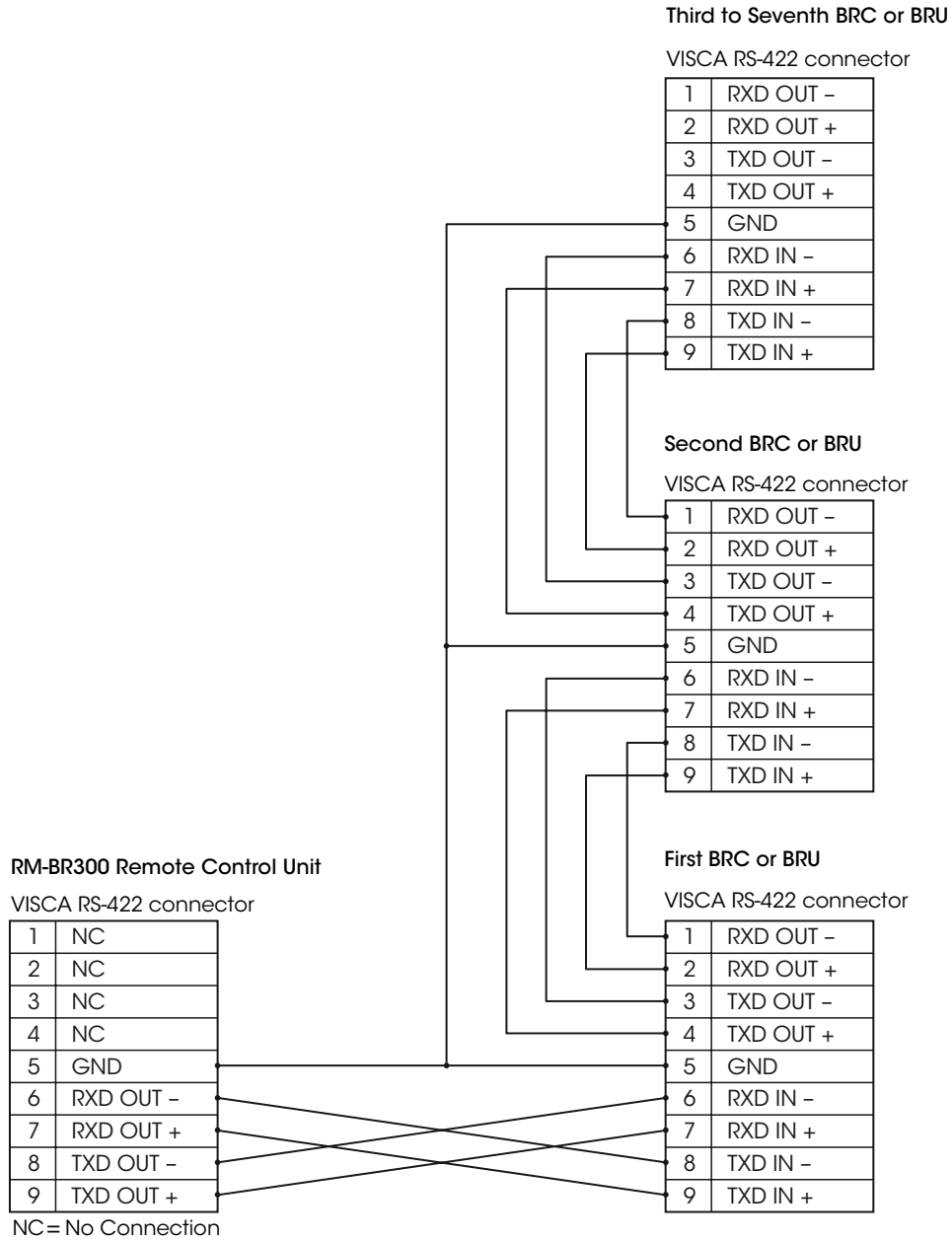



## 12.8 CCFC Cable Information: CCFC-M100HG and CCFC-M100

The following provides summarized information on the CCFC cable used for the optical fiber connection between a BRC Series and its optical multiplex units.



CCFC-M100HG



CCFC-M100

### Features

The CCFC-M100HG and CCFC-M100 are 2-core multi-mode optical fiber cables of 100 m in length to connect a camera and an optical multiplex unit. You can transmit uncompressed digital data on these cables, including video, external sync, and camera control signals. The maximum distance is 1,000 m between the BRC-H700 and BRU-H700, and also between the BRC-Z700 and BRU-H700, using CCFC-M100HG cables. The maximum distance between is 500 m between the BRC-300/300P and BRU-300/300P, using CCFC-M100 cables.

### Maximum Cable Length between a BRC Series Camera and its Optical Multiplex Unit

BRC Series	The BRC-H700	The BRC-Z700	The BRC-300
Cables	The BRC-H700 with the BRU-H700	The BRC-Z700 with the BRU-H700	The BRC-300 with the BRU-300
CCFC-M100	No	No	500 m
CCFC-M100HG	1,000 m	1,000 m	600 m *

\* The CCFC-M100HG can be used between the BRC-300/300P and BRU-300/300P. In this case, the maximum distance is 600 m.

### Recommended Optical Fiber Cables and Connectors

The following information will help you to make your own cables.

#### Connector

Duplex LC Connector Plug

Insertion Loss: Max 0.3dB

#### BRC-H700/Z700 – BRU-H700

Grade Index-type (GI-type)

Flame-retardant Multi-Mode Optical Fiber Cable

Transmission Loss: Less than 3.0 dB at wave length  $\lambda=0.85\mu\text{m}$

Transmission Band Width: More than 1,500 MHz·km at wave length  $\lambda=0.85\mu\text{m}$  by DMD Test Method

#### BRC-300/300P – BRU-300/300P

Grade Index-type (GI-type)

Flame-retardant Multi-Mode Optical Fiber Cable

Transmission Loss: Less than 3.0 dB at wave length  $\lambda=0.85\mu\text{m}$

Transmission Band Width: More than 500 MHz·km at wave length  $\lambda=0.85\mu\text{m}$  by DMD Test Method

**Note** The protocol manual (interface manual ) for each product are available. Please contact to the regional headquarters.

# 13

## Installing the Camera in a High Position

Using the supplied ceiling brackets, wire rope and screws, and the attachment materials (not supplied), you can attach the camera to a ceiling or on a shelf, etc. in a high position. When you install the camera, always install it on a level ceiling or shelf, etc. If you have to install it on an incline, make sure that the inclination is within  $\pm 15$  degrees, so that the pan/tilt performance is guaranteed.

- Caution**
- When you attach the camera to a ceiling or shelf, etc. in a high position, entrust the installation to an experienced contractor or installer.
  - Attach the camera to the ceiling or shelf, etc. firmly, after making sure the ceiling, shelf, etc. and the attachment materials (not including the supplied accessories) are strong enough to bear a weight of 60 kg (132 lb 4 oz). If the ceiling or shelf, etc. is not strong enough, the camera may fall and cause serious injury.
  - Be sure to attach the supplied wire rope to prevent the camera from falling.
  - Check periodically, at least once a year, to ensure that the connection has not loosened. If conditions warrant, make this periodic check more frequently.

### Before installation

After deciding the shooting direction, make the required holes for the ceiling bracket (B) and connecting cables on the ceiling or shelf, etc. For the dimensions of the ceiling bracket (B), see page 42.

- Note**
- The connecting cables cannot be passed through the ceiling bracket (A). A hole for the wiring is required in the ceiling or on a shelf, etc. behind where the camera is to be installed.
  - Do not attach any object other than the camera to the ceiling brackets.
  - The ceiling bracket cannot be attached to the junction box when installing the camera on a ceiling.

### Installation on a ceiling (example)

- 1 Set IMG-FLIP to ON in the SYSTEM menu.
- 2 Remove the four screws on the bottom of the camera to remove the four feet.

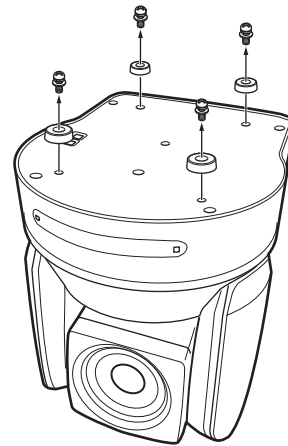

- 3 Attach the ceiling bracket (A) to the bottom of the camera using the supplied four screws (3M3 x 8). Position the a hole for screwing on the ceiling bracket (A) to the front of the camera as illustrated, align the screw holes on the ceiling bracket with those on the bottom of the camera, then attach the bracket to the camera.

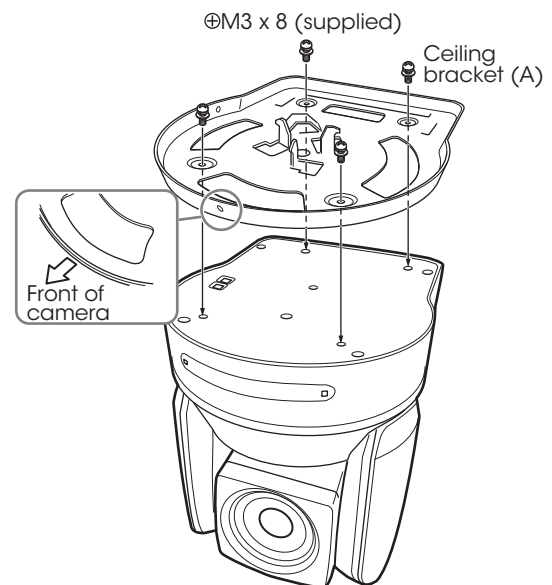

- Note** For attaching the camera to the ceiling bracket, use only the supplied screws. Using other screws may damage the camera.

- 4** Attach the attachment materials (not supplied) to the ceiling bracket (B), and install the bracket on the ceiling. Align the hole on the ceiling bracket (B) in the direction where the front of the camera will be positioned later.

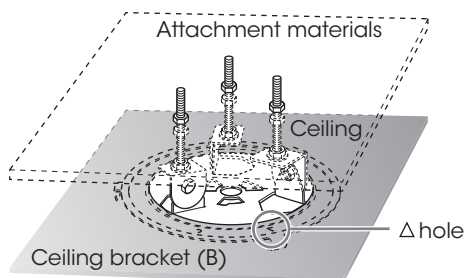

- 5** Attach the wire rope to the materials near the ceiling. Use an M5 (3/16 inch) hexagon socket head cap screw (not supplied). Attach the wire rope to an area independent of the area where the ceiling bracket is attached.

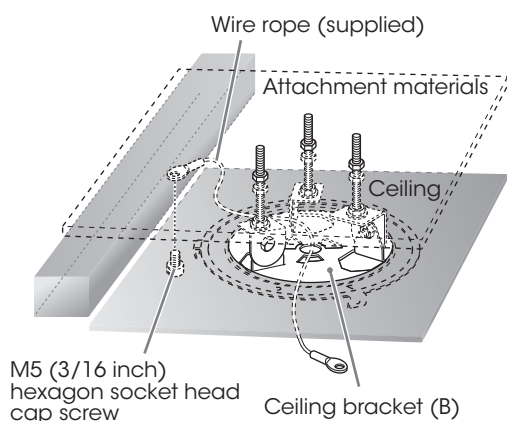

- 6** Attach the wire rope to the ceiling bracket (A). Pass the wire rope through the fixing hole and attach its end to the attachment hole on the bracket using the supplied one screw (3M4 x 8).

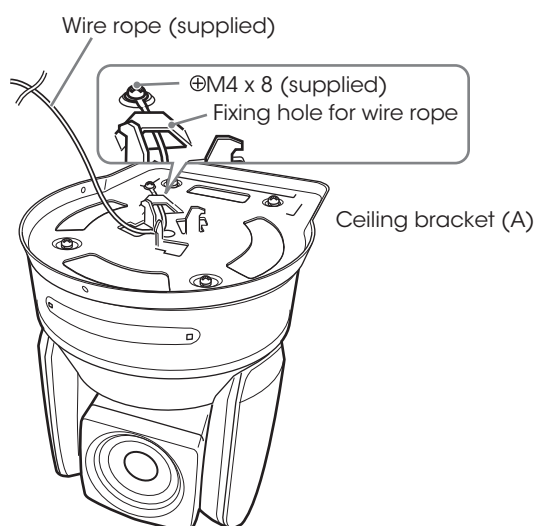

**Caution** For attaching the wire rope to the bracket, use only the supplied screw. Using another screw may disable the function of the wire rope.

- 7** Insert the protrusions on the ceiling bracket (A) into the spaces prepared in the ceiling bracket (B) with the hole in the front of the ceiling bracket (A) aligned with the hole on the ceiling bracket (B), and temporarily attach them by turning the ceiling bracket (A) with the camera clockwise.

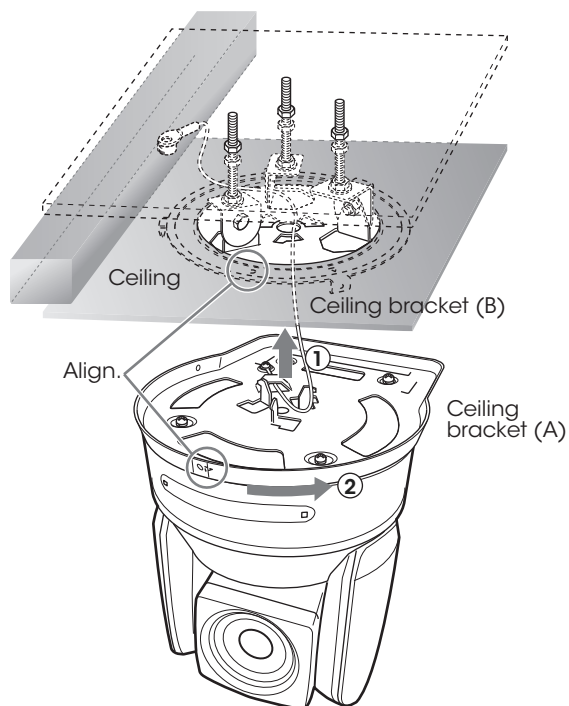

- 8** Secure the ceiling brackets (A) and (B) using the supplied three screws (3M3 x 8).

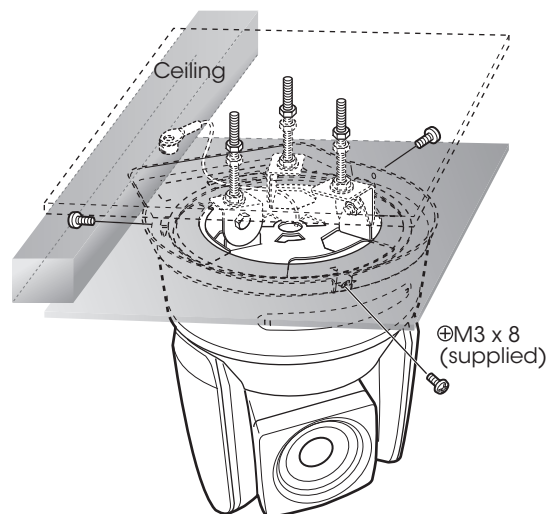

- 9 Connect the cables to the connectors on the rear of the camera.

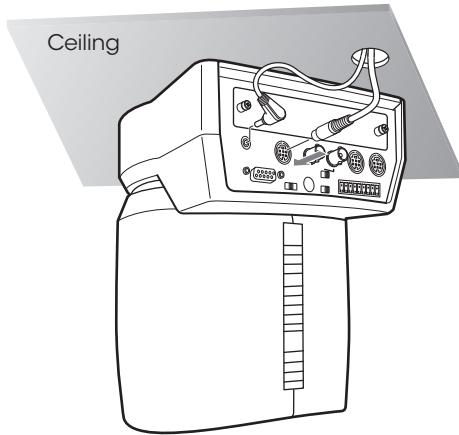

**Note** Take the proper steps to ensure that the load of the cables connected does not cause problems.

- 10 The SONY and/or HD nameplates can be turned upside down, if necessary.

### To remove the camera

- 1 Remove the three screws used to attach the camera in step 8 of "Installation on a ceiling (example)."
- 2 Turn the camera with the bracket counterclockwise to remove.

### Installation on a shelf, etc. in a high position (example)

- 1 Remove the four screws on the bottom of the camera to remove the four feet.

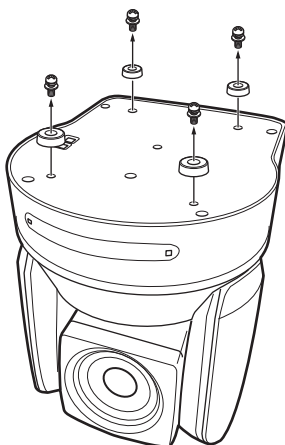

- 2 Attach the ceiling bracket (A) to the bottom of the camera using the supplied four screws (3M3 x 8). Position the hole for screwing on the ceiling bracket (A) to the front of the camera as illustrated, align the screw holes on the ceiling bracket with those on the bottom of the camera, then attach the bracket to the camera.

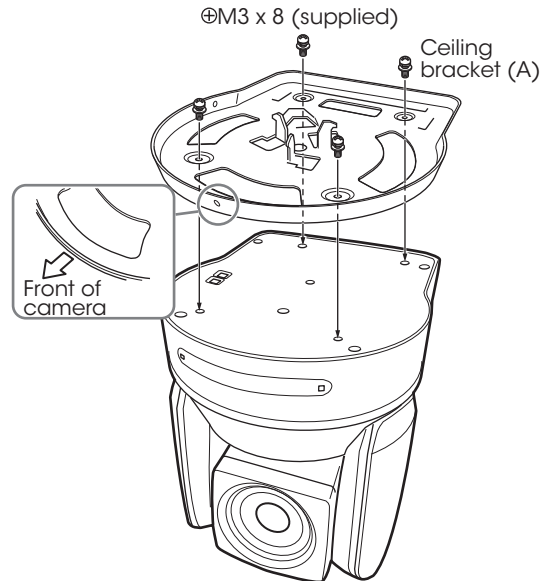

**Note** For attaching the camera to the ceiling bracket, use only the supplied screws. Using other screws may damage the camera.

- 3 Attach the supplied wire rope to the ceiling bracket (A). Pass the wire rope through the fixing hole and attach its end to the attachment hole on the bracket using the supplied one screw (3M4 x 8).

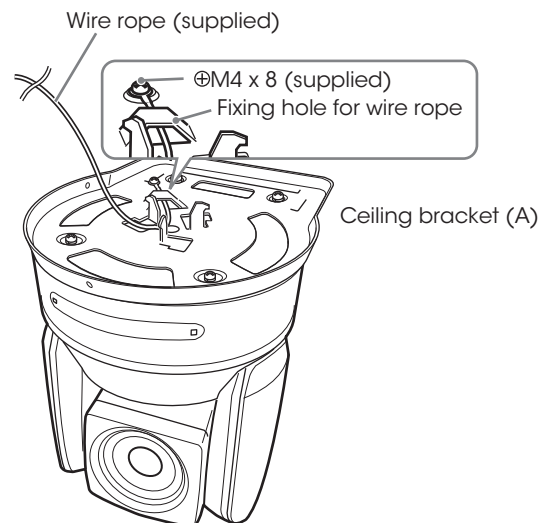

**Caution** For attaching the wire rope to the bracket, use only the supplied screw. Using another screw may disable the function of the wire rope.

**4** Attach the ceiling bracket (B) to a shelf, etc. on which the camera is to be installed. Use four screws (not supplied) appropriate for the materials of the shelf, etc. Align the hole on the ceiling bracket (B) in the direction where the front of the camera will be positioned later.

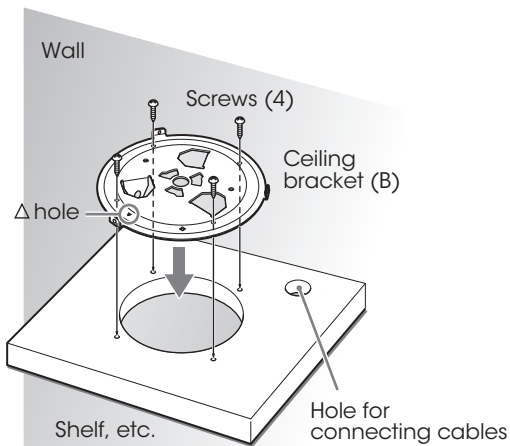

**5** Attach the other end of the wire rope to the material near the shelf, etc. Use an M5 (3/16 inch) hexagon socket head cap screw (not supplied). Attach the wire rope to the material independent of the shelf, etc. where the ceiling bracket (B) is attached.



**6** Insert the protrusions on the ceiling bracket (A) into the spaces prepared in the ceiling bracket (B) with the a hole in the front of the ceiling bracket (A) aligned with the hole on the ceiling bracket (B), and temporarily attach them by turning the ceiling bracket (A) with the camera counterclockwise.

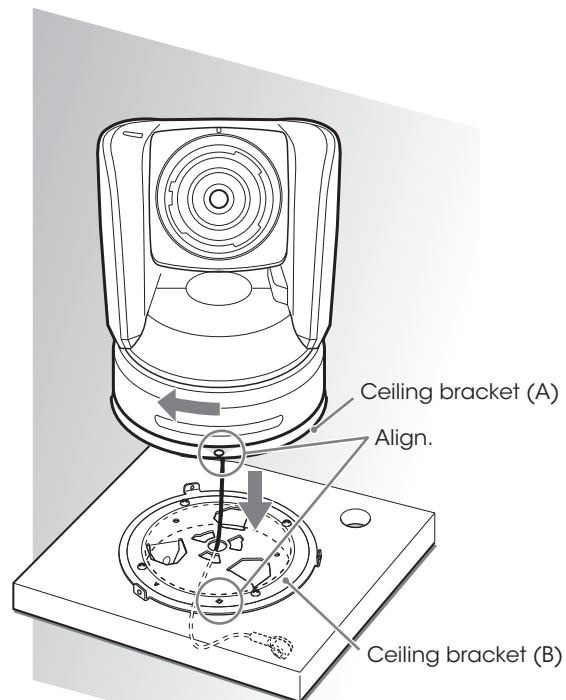

**7** Secure the ceiling brackets (A) and (B) using the supplied three screws (3M3 x 8).

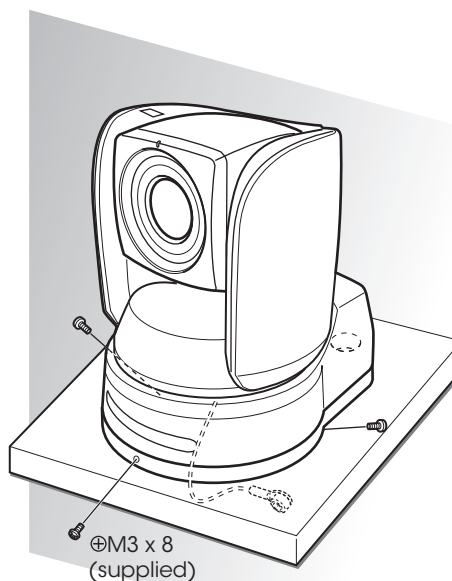

- 8 Connect the cables to the connectors on the rear of the camera.

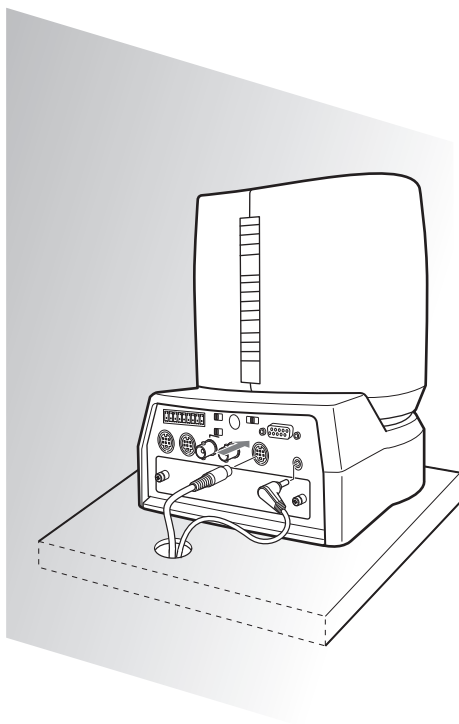

**Note** Take the proper steps to ensure that the load of the cables connected does not cause problems.

### To remove the camera

- 1 Remove the three screws used to attach the camera in step 7 of "Installation on a shelf, etc. in a high position (example)."
- 2 Turn the camera with the bracket clockwise to remove.

# SONY

---

**Distributed by**

© 2008 Sony Corporation. All rights reserved.  
Reproduction in whole or in part without written permission is prohibited.  
Design, features, and specifications are subject to change without notice.  
All non-metric weights and measurements are approximate.  
Some images in this catalog are simulated.  
Sony is a registered trademark of Sony Corporation.  
Advanced HAD, VISCA, Remote Commander, ClearVid CMOS, i.LINK, and the  
i.LINK logo are trademarks of Sony Corporation  
HDV and the HDV logo are trademarks of Sony Corporation and Victor  
Company of Japan, Limited.  
Vario-Sonnar T\* is a trademark of Carl Zeiss AG.